

SINCE
19
89

















**LISTINO PREZZI
PRICE LIST
LIST DE PRIX
LISTA DE PRECIOS**



2019 V.2

**MADE
TO
LAST.**



MOVEO - CATALOGO / CATALOGUE / CATALOGUE / CATÁLOGO PAG. 8

	MOVEO 230V 600kg - Motoriduttore 230 Vac per cancelli scorrevoli fino a 600 Kg. Centralina BIOS1 incorporata. <u>Contropiastra di fissaggio inclusa.</u> - 230 Vac gearmotor for sliding gates up to a weight of 600 Kg. BIOS1 control unit on-board. <u>Backing plate included.</u> - Motoréducteur 230 Vac pour portails coulissants jusqu'à 600 Kg. Centrale BIOS1 incorporée. <u>Contre plaque de fixation inclus.</u> - Motorreductor 230 Vac para puertas correderas de hasta 600 Kg. Cuadro de mando BIOS1 incorporado. <u>Placa de fijación incluida.</u>		12007920	€ 400,00
			12007926*	€ 425,00
	MOVEO 230V 800kg - Motoriduttore 230 Vac per cancelli scorrevoli fino a 800 Kg. Centralina BIOS1 incorporata. <u>Contropiastra di fissaggio inclusa.</u> - 230 Vac gearmotor for sliding gates up to a weight of 800 Kg. BIOS1 control unit on-board. <u>Backing plate included.</u> - Motoréducteur 230 Vac pour portails coulissants jusqu'à 800 Kg. Centrale BIOS1 incorporée. <u>Contre plaque de fixation inclus.</u> - Motorreductor 230 Vac para puertas correderas de hasta 800 Kg. Cuadro de mando BIOS1 incorporado. <u>Placa de fijación incluida.</u>		12007922	€ 480,00
			12007926*	€ 505,00
MOVEO 230V 800kg: Disponibile da giugno 2019 / Available from June 2019 / Disponible depuis juin 2019 / Disponible desde junio 2019				
	MOVEO 24V 700kg - Motoriduttore 24 Vdc per cancelli scorrevoli fino a 700 Kg. Centralina BIOS1 24 incorporata. <u>Contropiastra di fissaggio inclusa.</u> - 24 Vdc gearmotor for sliding gates up to a weight of 700 Kg. BIOS1 24 control unit on-board. <u>Backing plate included.</u> - Motoréducteur 24 Vdc pour portails coulissants jusqu'à 700 Kg. Centrale BIOS1 24 incorporée. <u>Contre plaque de fixation inclus.</u> - Motorreductor 24 Vdc para puertas correderas de hasta 700 Kg. Cuadro de mando BIOS1 24 incorporado. <u>Placa de fijación incluida.</u>		12007950	€ 448,00
			*	€ 473,00
	MOVEO 120V 600kg - Motoriduttore 120 Vac per cancelli scorrevoli fino a 600 Kg. Centralina BIOS1 incorporata. <u>Contropiastra di fissaggio inclusa.</u> - 120 Vac gearmotor for sliding gates up to a weight of 600 Kg. BIOS1 control unit on-board. <u>Backing plate included.</u> - Motoréducteur 120 Vac pour portails coulissants jusqu'à 600 Kg. Centrale BIOS1 incorporée. <u>Contre plaque de fixation inclus.</u> - Motorreductor 120 Vac para puertas correderas de hasta 600 Kg. Cuadro de mando BIOS1 incorporado. <u>Placa de fijación incluida.</u>		12007930	€ 419,00
			12007935*	€ 444,00
	MOVEO 24V 500kg FAST - Motoriduttore 24 Vdc per cancelli scorrevoli fino a 500 Kg. Centralina BIOS1 24 incorporata. <u>Contropiastra di fissaggio inclusa.</u> - 24 Vdc gearmotor for sliding gates up to a weight of 500 Kg. BIOS1 24 control unit on-board. <u>Backing plate included.</u> - Motoréducteur 24 Vdc pour portails coulissants jusqu'à 500 Kg. Centrale BIOS1 24 incorporée. <u>Contre plaque de fixation inclus.</u> - Motorreductor 24 Vdc para puertas correderas de hasta 500 Kg. Cuadro de mando BIOS1 24 incorporado. <u>Placa de fijación incluida.</u>		12007960	€ 480,00
			*	€ 505,00
MOVEO 24V 500kg FAST: Disponibile a breve / Available soon / Bientôt disponible / Disponible pronto				
* VERSIONE CON FINECORSA MAGNETICO, MAGGIORAZIONE € 25,00 / VERSION WITH MAGNETIC LIMIT SWITCH, PRICE SUPPLEMENT € 25,00 / * VERSION AVEC FIN DE COURSE MAGNÉTIQUE, SUPPLÉMENT DU € 25,00 / VERSIÓN CON FINAL DE CARRERA MAGNÉTICO, AUMENTO DE PRECIO DE € 25,00				
	- Contropiastra di fissaggio adatta per MOVEO. - Backing plate for MOVEO. - Contre plaque de fixation pour MOVEO. - Placa de fijación apta para MOVEO.		54000815	€ 16,00
	- Cremagliera in nylon con anima in acciaio 20x28x1000 mm, alette di fissaggio e viteria. - Nylon rack with steel core 20x28x1000mm, fixing gills and set of screws. - Crémaillère en nylon 20x28x1000 mm avec âme en acier, ailettes de fixation et gamme de vis. - Cremallera en nylon con núcleo en acero 20x28x1000 mm, aletas de fijación y tornillos.		12007190	€ 15,00
	- Cremagliera in acciaio zincato 30x12x1000 mm con distanziali e viteria. - Galvanized steel rack 30x12x1000mm with spacers and set of screws. - Crémaillère en acier galvanisé 30x12x1000 mm avec entretoises intégrées et gamme de vis. - Cremallera galvanizada 30x12x1000 mm con distanciadores y tornillos.		64100005	€ 18,00

	<p>BLUETOOTH</p> <ul style="list-style-type: none"> - Modulo Bluetooth per centraline BIOS1 e BIOS2. - Bluetooth module for BIOS1 and BIOS2 control units. - Module Bluetooth pour centrales BIOS1 et BIOS2. - Módulo Bluetooth para cuadros de mando BIOS1 y BIOS2. 			12006730	€ 95,00
	<p>24CBA BOX MOVEO / KALOS XL 24V</p> <ul style="list-style-type: none"> - Scheda carica batterie 24V ad innesto con controllo elettronico della carica. - Plug-in 24V battery charger card with electronic control of charge level. - Carte chargeur de batterie 24V embrochable avec contrôle électronique de la charge. - Tarjeta enchufable para cargador de baterías 24V con control electrónico de la carga. 	<p>Opzionale per BIOS1 24V Optional for BIOS1 24V Optionnel pour BIOS1 24V Opcional para BIOS1 24V</p>		12000782	€ 32,00
	<p>BATTERIA / BATTERY / BATTERIE / BATERÍA</p> <ul style="list-style-type: none"> - Batteria ricaricabile 12V, 1.3Ah. Dim. (mm) W x D x H = 98 X 45 X 50. - Rechargeable battery 12V, 1.3Ah. Dim. (mm) W x D x H = 98 X 45 X 50. - Batterie rechargeable 12V, 1.3Ah. Dim. (mm) W x D x H = 98 X 45 X 50. - Batería recargable 12V, 1.3Ah. Dim. (mm) W x D x H = 98 X 45 X 50. 			61400053	€ 28,00

Modulo caricabatterie in 24V box con controllo elettronico della carica (opzionale)

24V backup battery charger module with electronic charge control (optional)

Módulo de cargador de batería enchufable de 24 V con control de carga electrónico (opcional)

Carte chargeur de batteries de secours 24V embrochable avec contrôle électronique de la charge (optionnel)

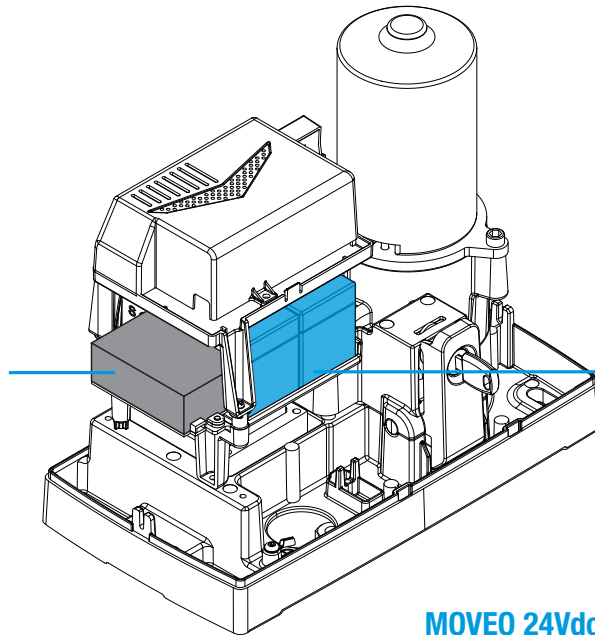

MOVEO 24Vdc







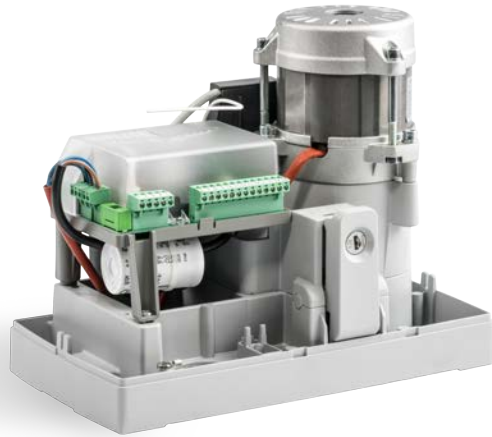

Batterie di soccorso.
2 batterie da 1.3Ah (opzionali)



Emergency batteries.
2 batteries da 1.3Ah (optional)



Baterias de emergencia.
2 baterias de 1.3Ah (opcional)

Batteries de secours.
2 batteries 1.3Ah (optionnel)









	<p>KALOS XL 230V 800kg</p> <ul style="list-style-type: none"> - Motoriduttore 230 Vac per cancelli scorrevoli fino a 800 Kg (KALOS XL 800). Centralina BIOS1 incorporata. Contropiastra di fissaggio inclusa. - 230 Vac gearmotor for sliding gates up to a weight of 800 Kg (KALOS XL 800). BIOS1 control unit on-board. Backing plate included. - Motoréducteur 230 Vac pour portails coulissants jusqu'à 800 Kg (KALOS XL 800). Centrale BIOS1 incorporée. Contre plaque de fixation inclus. - Motorreductor 230 Vac para puertas correderas de hasta 800 Kg (KALOS XL 800). Cuadro de mando BIOS1 incorporado. Placa de fijación incluida. 		12007882	€ 500,00
			12007872*	€ 525,00
Disponibile fino a giugno 2019 / Available until June 2019 / Disponible jusqu'à juin 2019 / Disponible hasta junio 2019				
	<p>KALOS XL 230V 1200kg</p> <ul style="list-style-type: none"> - Motoriduttore 230 Vac per cancelli scorrevoli fino a 1200 Kg. Centralina BIOS1 incorporata. Contropiastra di fissaggio inclusa. - 230 Vac gearmotor for sliding gates up to a weight of 1200 Kg. BIOS1 control unit on-board. Backing plate included. - Motoréducteur 230 Vac pour portails coulissants jusqu'à 1200Kg. Centrale BIOS1 incorporée. Contre plaque de fixation inclus. - Motorreductor 230 Vac para puertas correderas de hasta 1200kg. Cuadro de mando BIOS1 incorporado. Placa de fijación incluida. 		12007881	€ 540,00
			12007871*	€ 565,00
	<p>KALOS XL 230V 1500kg</p> <ul style="list-style-type: none"> - Motoriduttore 230 Vac per cancelli scorrevoli fino a 1500 Kg. Centralina BIOS1 incorporata. Contropiastra di fissaggio inclusa. - 230 Vac gearmotor for sliding gates up to a weight of 1500 Kg. BIOS1 control unit on-board. Backing plate included. - Motoréducteur 230 Vac pour portails coulissants jusqu'à 1500Kg. Centrale BIOS1 incorporée. Contre plaque de fixation inclus. - Motorreductor 230 Vac para puertas correderas de hasta 1500kg. Cuadro de mando BIOS1 incorporado. Placa de fijación incluida. 	NEW	12007884	€ 630,00
	<p>KALOS XL 24V 1000kg</p> <ul style="list-style-type: none"> - Motoriduttore 24 Vdc per cancelli scorrevoli fino a 1000 Kg. Centralina BIOS1 24 incorporata. Contropiastra di fissaggio inclusa. - 24 Vdc gearmotor for sliding gates up to a weight of 1000 Kg. BIOS1 24 control unit on-board. Backing plate included. - Motoréducteur 24 Vdc pour portails coulissants jusqu'à 1000 Kg. Centrale BIOS1 24 incorporée. Contre plaque de fixation inclus. - Motorreductor 24 Vdc para puertas correderas de hasta 1000 Kg. Cuadro de mando BIOS1 24 incorporado. Placa de fijación incluida. 		12007886	€ 600,00
			12007894*	€ 625,00
	<p>KALOS XL 24V 600kg FAST</p> <ul style="list-style-type: none"> - Motoriduttore 24 Vdc per cancelli scorrevoli fino a 600 Kg. Centralina BIOS1 24 incorporata. Velocità fino a 18m/minuto. Contropiastra di fissaggio inclusa. - 24 Vdc gearmotor for sliding gates up to a weight of 600 Kg. BIOS1 24 control unit on-board. Speed up to 18m/ minute. Backing plate included. - Motoréducteur 24 Vdc pour portails coulissants jusqu'à 600 Kg. Centrale BIOS1 24 incorporée. Vitesse jusqu'à 18m / minutes. Contre plaque de fixation inclus. - Motorreductor 24 Vdc para puertas correderas de hasta 600 Kg. Cuadro de mando BIOS1 24 incorporado. Velocidad hasta 18m / minutos. Placa de fijación incluida. 	NEW	12007877	€ 632,00
			12007841*	€ 657,00
	<p>KALOS XL 120V 1000kg</p> <ul style="list-style-type: none"> - Motoriduttore 120 Vac per cancelli scorrevoli fino a 1000 Kg. Centralina BIOS1 incorporata. Contropiastra di fissaggio inclusa. - 120Vac gearmotor for sliding gates up to a weight of 1000 Kg. BIOS1 control unit on-board. Backing plate included. - Motoréducteur 24 Vdc pour portails coulissants jusqu'à 1000 Kg. Centrale BIOS1 incorporée. Contre plaque de fixation inclus. - Motorreductor 24 Vdc para puertas correderas de hasta 1000 Kg. Cuadro de mando BIOS1 incorporado. Placa de fijación incluida. 		12007884	€ 520,00
			12007863*	€ 545,00
* VERSIONE CON FINECORSA MAGNETICO, MAGGIORAZIONE € 25,00 / *VERSION WITH MAGNETIC LIMIT SWITCH, PRICE SUPPLEMENT € 25,00 / * VERSION AVEC FIN DE COURSE MAGNÉTIQUE, SUPPLÉMENT DU € 25,00 / *VERSIÓN CON FINAL DE CARRERA MAGNÉTICO, AUMENTO DE PRECIO DE € 25,00				
	<ul style="list-style-type: none"> - Cremagliera in nylon con anima in acciaio 20x28x1000 mm, alette di fissaggio e viteria. - Nylon rack with steel core 20x28x1000mm, fixing gills and set of screws. - Crémaillère en nylon 20x28x1000 mm avec âme en acier, ailettes de fixation et gamme de vis. - Cremallera en nylon con núcleo en acero 20x28x1000 mm, aletas de fijación y tornillos. 	NEW	12007190	€ 15,00
	<ul style="list-style-type: none"> - Cremagliera in acciaio zincato 30x12x1000 mm con distanziali e viteria. - Galvanized steel rack 30x12x1000mm with spacers and set of screws. - Crémaillère en acier galvanisé 30x12x1000 mm avec entretoises intégrées et gamme de vis. - Cremallera galvanizada 30x12x1000 mm con distanciadores y tornillos. 		64100005	€ 18,00

	BLUETOOTH - Modulo Bluetooth per centraline BIOS1 e BIOS2. - Bluetooth module for BIOS1 and BIOS2 control units. - Module Bluetooth pour centrales BIOS1 et BIOS2. - Módulo Bluetooth para cuadros de mando BIOS1 y BIOS2.		12006730	€ 95,00
	24CBA BOX MOVEO / KALOS XL 24V - Scheda carica batterie 24V ad innesto con controllo elettronico della carica. - Plug-in 24V battery charger card with electronic control of charge level. - Carte chargeur de batterie 24V embrochable avec contrôle électronique de la charge. - Tarjeta enchufable para cargador de baterías 24V con control electrónico de la carga.	Ozionale per BIOS1 24V Optional for BIOS1 24V Optionnel pour BIOS1 24V Opcional para BIOS1 24V	12000782	€ 32,00
	BATTERIA / BATTERY / BATTERIE / BATERÍA - Batteria ricaricabile 12V, 1.3Ah. Dim. (mm) W x D x H = 98 X 45 X 50. - Rechargeable battery 12V, 1.3Ah. Dim. (mm) W x D x H = 98 X 45 X 50. - Batterie rechargeable 12V, 1.3Ah. Dim. (mm) W x D x H = 98 X 45 X 50. - Batería recargable 12V, 1.3Ah. Dim. (mm) W x D x H = 98 X 45 X 50.		61400053	€ 28,00





	- Cremagliera in acciaio zincato 22x22x2000 mm. - Galvanized steel rack 22x22x2000 mm. - Crémaillère en acier galvanisé 22x22x2000 mm. - Cremallera galvanizada 22x22x2000 mm.		64100006	€ 44,00/2mt
	- Contropiastra di fissaggio rialzata. - Raised backing plate. - Contre plaque de fixation élevé. - Placa de fijación elevado.		54000650	€ 22,00



BIG2.2 - CATALOGO / CATALOGUE / CATALOGUE / CATÁLOGO PAG. 14

	BIG2.2 con BIOS1 - Motoriduttore 230 Vac per cancelli scorrevoli fino a 2200 Kg. Centralina BIOS1 incorporata. <u>Contropiastra di fissaggio inclusa.</u> - 230 Vac gearmotor for sliding gates up to a weight of 2200 Kg. BIOS1 control unit on-board. <u>Backing plate included.</u> - Motoréducteur 230 Vac pour portails coulissants jusqu'à 2200 Kg. Centrale BIOS1 incorporée. <u>Contre plaque de fixation inclus.</u> - Motorreductor 230 Vac para puertas correderas de hasta 2200 Kg. Cuadro de mando BIOS1 incorporado. <u>Placa de fijación incluida.</u>		12007168	€ 715,00
	BIG2.2 con CT INVERTER - Motoriduttore 230 Vac per cancelli scorrevoli fino a 2200 Kg. Centralina CT INVERTER incorporata. <u>Contropiastra di fissaggio inclusa. Ricevitore B.RO22W LED 2ch incluso.</u> - 230 Vac gearmotor for sliding gates up to a weight of 2200 Kg. CT INVERTER control unit on-board. <u>Backing plate included. B.RO22W LED 2ch receiver included.</u> - Motoréducteur 230 Vac pour portails coulissants jusqu'à 2200 Kg. Centrale CT INVERTER incorporée. <u>Contre plaque de fixation inclus. Récepteur B.RO22W LED 2ch inclus.</u> - Motorreductor 230 Vac para puertas correderas de hasta 2200 Kg. Cuadro de mando CT INVERTER incorporado. <u>Placa de fijación incluida. Receptor B.RO22W LED 2ch incluido.</u>		12007806	€ 970,00
	BLUETOOTH - Modulo Bluetooth per centraline BIOS1 e BIOS2. - Bluetooth module for BIOS1 and BIOS2 control units. - Module Bluetooth pour centrales BIOS1 et BIOS2. - Módulo Bluetooth para cuadros de mando BIOS1 y BIOS2.		12006730	€ 95,00
	- Cremagliera in acciaio zincato 22x22x2000 mm. - Galvanized steel rack 22x22x2000 mm. - Crémaillère en acier galvanisé 22x22x2000 mm. - Cremallera galvanizada 22x22x2000 mm.		64100006	€ 44,00/2mt







	<p>WINTER</p> <ul style="list-style-type: none"> - Scheda riscaldatore controllata in temperatura grazie ad una sonda di temperatura per motori 230 Vac. Regolazione tensione di riscaldamento attraverso comodi ponticelli. - Heater card for 230 Vac motors controlled through a thermostatic probe. Setting of heater voltage by comfortable jumper connections. - Carte de préchauffement pour moteurs 230 Vac contrôlée par une sonde de température. Régulation tension de chauffage grâce à des confortables petits ponts. - Tarjeta calentadora. Control de temperatura por una sonda termostática para motores 230 Vac. Ajuste tensión de calefacción a través de cómodos puentecillos. 	12000770	€ 90,00
	<ul style="list-style-type: none"> - Contropiastra di fissaggio per BIG2.2. - Backing plate for BIG2.2. - Contre plaque de fixation pour BIG2.2. - Placa de fijación apta para BIG2.2. 	64100210	€ 46,00
	<p>B.RO22W LED 2ch</p> <ul style="list-style-type: none"> - Ricevitore rolling code 2 canali con connettore molex a 10 vie (ad innesto). Relè con selezione funzionamento impulsivo, passo-passo o temporizzato. - 2 channels rolling code receiver with 10 pins molex connector. Relay with selection of impulse, step by step or timer controlled function. - Récepteur rolling code 2 canaux avec connecteur à 10 voies (embrochable). Relais avec selection fonctionnement impulsif, pas à pas et temporisé. - Receptor rolling code con conector molex de 10 vías (enchufable). Relé con selección funcionamiento con impulsos, paso-paso o temporizado. 	12006471	€ 45,00

INDUSTRIAL - CATALOGO / CATALOGUE / CATALOGUE / CATÁLOGO PAG. 16-19

	<p>I2500/B</p> <ul style="list-style-type: none"> - Motoriduttore 230 Vac per cancelli scorrevoli fino a 2500 Kg. Centralina BIOS1 incorporata. - <u>Contropiastra di fissaggio inclusa.</u> - 230 Vac gearmotor for sliding gates up to a weight of 2500 Kg. BIOS1 control unit on-board. - <u>Backing plate included.</u> - Motoréducteur 230 Vac pour portails coulissants jusqu'à 2500 Kg. Centrale BIOS1 incorporée. - <u>Contre plaque de fixation inclus.</u> - Motorreductor 230 Vac para puertas correderas de hasta 2500 Kg. Cuadro de mando BIOS1 incorporado. - <u>Placa de fijación incluida.</u> 	12007101	€ 1.050,00
	<p>I2500/I</p> <ul style="list-style-type: none"> - Motoriduttore 230 Vac per cancelli scorrevoli fino a 2500 Kg. Centralina CT INVERTER incorporata. - <u>Contropiastra di fissaggio inclusa. Ricevitore B.RO22W LED 2ch incluso.</u> - 230 Vac gearmotor for sliding gates up to a weight of 2500 Kg. CT INVERTER control unit on-board. - <u>Backing plate included. B.RO22W LED 2ch receiver included.</u> - Motoréducteur 230 Vac pour portails coulissants jusqu'à 2500 Kg. Centrale CT INVERTER incorporée. - <u>Contre plaque de fixation inclus. Récepteur B.RO22W LED 2ch inclus.</u> - Motorreductor 230 Vac para puertas correderas de hasta 2500 Kg. Cuadro de mando CT INVERTER incorporado. - <u>Placa de fijación incluida. Receptor B.RO22W LED 2ch incluido.</u> 	12007102	€ 1.320,00
	<p>I3600 MAX</p> <ul style="list-style-type: none"> - Motoriduttore monofase (230 Vac) per cancelli scorrevoli fino a 3600 Kg. Centralina CT INVERTER incorporata. - <u>Contropiastra di fissaggio inclusa. Ricevitore B.RO22W LED 2ch incluso.</u> - Single-phase gearmotor (230 Vac) for sliding gates up to a weight of 3600 Kg. CT INVERTER control unit on-board. - <u>Backing plate included. B.RO22W LED 2ch receiver included.</u> - Motoréducteur (230 Vac) pour portails coulissants jusqu'à 3600 Kg. Centrale CT INVERTER incorporée. - <u>Contre plaque de fixation inclus. Récepteur B.RO22W LED 2ch inclus.</u> - Motorreductor monofásico (230 Vac) para puertas correderas de hasta 3600 Kg. Cuadro de mando CT INVERTER incorporado. - <u>Placa de fijación incluida. Receptor B.RO22W LED 2ch incluido.</u> 	12007106	€ 3.500,00
	<p>BLUETOOTH</p> <ul style="list-style-type: none"> - Modulo Bluetooth per centraline BIOS1 e BIOS2. - Bluetooth module for BIOS1 and BIOS2 control units. - Module Bluetooth pour centrales BIOS1 et BIOS2. - Módulo Bluetooth para cuadros de mando BIOS1 y BIOS2. 	12006730	€ 95,00





	<ul style="list-style-type: none"> - Cremagliera in acciaio zincato 22x22x2000 mm. - Galvanized steel rack 22x22x2000 mm. - Crémaillère en acier galvanisé 22x22x2000 mm. - Cremallera galvanizada 22x22x2000 mm. 	64100006	€ 44,00/2mt
	<p>B.R022W LED 2ch</p> <ul style="list-style-type: none"> - Ricevitore rolling code 2 canali con connettore molex a 10 vie (ad innesto). Relé con selezione funzionamento impulsivo, passo-passo o temporizzato. - 2 channels rolling code receiver with 10 pins molex connector. Relay with selection of impulse, step by step or timer controlled function. - Récepteur rolling code 2 canaux avec connecteur à 10 voies (embrochable). Relais avec selection fonctionnement impulsif, pas à pas et temporisé. - Receptor rolling code con conector molex de 10 vias (enchufable). Relé con selección funcionamiento con impulsos, paso-paso o temporizado. 	12006471	€ 45,00



KINEO 400 - CATALOGO / CATALOGUE / CATALOGUE / CATÁLOGO PAG. 22

	<p>KINEO 400 230V</p> <ul style="list-style-type: none"> - Motoriduttore 230 Vac per cancelli a battente fino a 3 metri. <u>Staffe di fissaggio incluse.</u> - 230 Vac gearmotor for wing gates up to 3 meters. <u>Mounting brackets included.</u> - Motoréducteur 230 Vac pour portails battants jusqu'à 3 mètres. <u>Supports de fixation inclus.</u> - Motorreductor 230 Vac para puertas a hojas de hasta 3 metros. <u>Soporte de fijación incluido.</u> 	12007446	€ 220,00
	<p>KINEO 400 24V</p> <ul style="list-style-type: none"> - Motoriduttore 24 Vdc per cancelli a battente fino a 2.5 metri. <u>Staffe di fissaggio incluse.</u> - 24 Vdc gearmotor for wing gates up to 2.5 meters. <u>Mounting brackets included.</u> - Motoréducteur 24 Vdc pour portails battants jusqu'à 2.5 mètres. <u>Supports de fixation inclus.</u> - Motorreductor 24 Vdc para puertas a hojas de hasta 2.5 metros. <u>Soporte de fijación incluido.</u> 	12007448	€ 221,00
	<p>KINEO 400 120V</p> <ul style="list-style-type: none"> - Motoriduttore 120 Vac per cancelli a battente fino a 3 metri. <u>Staffe di fissaggio incluse.</u> - 120 Vac gearmotor for wing gates up to 3 meters. <u>Mounting brackets included.</u> - Motoréducteur 120 Vac pour portails battants jusqu'à 3 mètres. <u>Supports de fixation inclus.</u> - Motorreductor 120 Vac para puertas a hojas de hasta 3 metros. <u>Soporte de fijación incluido.</u> 	12007447	€ 225,00
	<ul style="list-style-type: none"> - Fermo meccanico per KINEO 400. - Mechanical stop for KINEO 400. - Arrêt mécanique pour KINEO 400. - Paro mecánico para KINEO 400. 	64100233	€ 10,00
	<p>BIOS2</p> <ul style="list-style-type: none"> - Centralina per cancelli a 1 o 2 battenti 230Vac. Selezione funzioni tramite display. Con rilevamento ostacoli e autodiagnosi dei dispositivi di sicurezza. <u>Centrale con gestione di un trasmettitore tramite display.</u> - Control unit for 1 or 2 wings gate 230Vac. Functions selection through display. With obstacle detection and self-diagnosis of safety devices. <u>Control unit with managing of a transmitter through the display.</u> - Centrale de commande pour portails avec 1 ou 2 vantaux 230Vac. Sélections des fonctions par écran. Avec détection des obstacles et autodiagnostic des dispositifs de sécurité. <u>Centrale de commande avec gestion d'émetteurs à travers le display.</u> - Cuadro de mando para cancelas de 1 o 2 hojas 230Vac. Selección funciones a través de un display. Con detección de obstáculos y autodiagnósticos de los dispositivos. <u>Central con gestión de un transmisor a través del display.</u> 	12006515	€ 195,00
	<p>BIOS2 ECO</p> <ul style="list-style-type: none"> - Centralina per cancelli a 1 o 2 battenti 230Vac. Selezione funzioni tramite display. <u>Centrale con gestione di un trasmettitore tramite display. Connessione modulo Bluetooth non disponibile.</u> - Control unit for 1 or 2 wings gate 230Vac. Functions selection through display. <u>Control unit with managing of a transmitter through the display. Connection of Bluetooth module not available</u> - Centrale de commande pour portails avec 1 ou 2 vantaux 230Vac. Sélections des fonctions par écran. <u>Centrale de commande avec gestion d'émetteurs à travers le display. Connexion du module Bluetooth non disponible</u> - Cuadro de mando para cancelas de 1 o 2 hojas 230Vac. Selección funciones a través de un display. <u>Cuadro de mando con gestión de un transmisor a través del display. Conexión del módulo Bluetooth no está disponible.</u> 	12006531	€ 125,00
	<p>BIOS2 24V</p> <ul style="list-style-type: none"> - Centralina per cancelli a 1 o 2 battenti 24Vdc senza encoder. - Control unit for 1 or 2 wings gate 24Vdc without encoder. - Centrale de commande pour portails avec 1 ou 2 vantaux 24Vdc sans encodeur. - Cuadro de mando para el control de 1 o 2 hojas 24Vdc sin encoder. 	12006623	€ 245,00
	<p>BLUETOOTH</p> <ul style="list-style-type: none"> - Modulo Bluetooth per centraline BIOS1 e BIOS2. - Bluetooth module for BIOS1 and BIOS2 control units. - Module Bluetooth pour centrales BIOS1 et BIOS2. - Módulo Bluetooth para cuadros de mando BIOS1 y BIOS2. 	12006730	€ 80,00

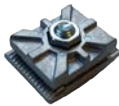

	R2 - Scheda espansione funzioni per la centralina di comando BIOS 2 ECO o BIOS2 24V. Uscita elettro serratura e luce di cortesia. - Card providing extended functions for the BIOS 2 ECO or BIOS2 24V control unit. Electrical lock and courtesy light output. - Carte d'expansion des fonctions pour BIOS2 ECO et BIOS2 24V. Sortie serrure électrique et de la lumière de courtoisie. - Tarjeta de expansión funciones para el cuadro de mando BIOS2 ECO y BIOS2 24V. Salida cerradura eléctrica y luz de cortesia.	12001703	€ 15,00	
	24CBA - Scheda carica batterie 24V ad innesto con controllo elettronico della carica. - 24V battery charger card with plug-in electronic control of charge level. - Carte chargeur de batterie 24V embrochable avec contrôle électronique de la charge. - Tarjeta enchufable para cargador de baterías 24V con control electrónico de la carga.	Ozionale per BIOS2 24V Optional for BIOS2 24V Optionnel pour BIOS2 24V Opcional para BIOS2 24V	12000780	€ 16,00
	KIT BATTERIE / BATTERIES KIT / KIT BATTERIES / KIT BATERIAS - 2 batterie ricaricabili 12V, 1.3Ah. Cavo 1 mt. - 2 rechargeable batteries 12V, 1.3Ah. 1mt cable. - 2 batteries rechargeable 12V, 1.3Ah. Câble 1mt. - 2 baterías recargable 12V, 1.3Ah. Cable 1 mt.	12000757	€ 67,00	



XTILUS - CATALOGO / CATALOGUE / CATALOGUE / CATÁLOGO PAG. 24

	XTILUS 230Vac - Motoriduttore 230 Vac per cancelli a battente fino a 3.5 metri. <u>Staffe di fissaggio incluse. Chiave sblocco DIN</u> - 230 Vac gearmotor for wing gates up to 3.5 meters. <u>Mounting brackets included. DIN unlock key</u> - Motoréducteur 230 Vac pour portails battants jusqu'à 3.5 mètres. <u>Supports de fixation inclus. Clé de déblocage DIN</u> - Motorreductor 230 Vac para puertas a hojas de hasta 3.5 metros. <u>Soporte de fijación incluido. Llave de desbloqueo DIN</u>	ANTRACITE ANTHRACITE ANTHRACITE ANTRACITA	12007408	€ 320,00
	XTILUS 24Vdc - Motoriduttore 24 Vdc per cancelli a battente fino a 3.5 metri. <u>Staffe di fissaggio incluse. Chiave sblocco DIN</u> - 24 Vdc gearmotor for wing gates up to 3.5 meters. <u>Mounting brackets included. DIN unlock key</u> - Motoréducteur 24 Vdc pour portails battants jusqu'à 3.5 mètres. <u>Supports de fixation inclus. Clé de déblocage DIN</u> - Motorreductor 24 Vdc para puertas a hojas de hasta 3.5 metros. <u>Soporte de fijación incluido. Llave de desbloqueo DIN</u>	ANTRACITE ANTHRACITE ANTHRACITE ANTRACITA	12007489	€ 330,00
	XTILUS 120Vac - Motoriduttore 120 Vac per cancelli a battente fino a 3.5 metri. <u>Staffe di fissaggio incluse. Chiave sblocco DIN</u> - 120 Vac gearmotor for wing gates up to 3.5 meters. <u>Mounting brackets included. DIN unlock key</u> - Motoréducteur 120 Vac pour portails battants jusqu'à 3.5 mètres. <u>Supports de fixation inclus. Clé de déblocage DIN</u> - Motorreductor 120 Vac para puertas a hojas de hasta 3.5 metros. <u>Soporte de fijación incluido. Llave de desbloqueo DIN</u>	ANTRACITE ANTHRACITE ANTHRACITE ANTRACITA	12007495	€ 336,00
- N. 1 Fermo meccanico di chiusura per XTILUS incluso - N. 1 Mechanical closing stop for XTILUS included - N. 1 Fin de course mécanique de fermeture pour XTILUS inclus - N. 1 Paro mecánico de cierre para XTILUS incluidas				
	- Fermo meccanico aggiuntivo di chiusura per XTILUS - Extra mechanical closing stop for XTILUS - Fin de course mécanique de fermeture supplémentaire pour XTILUS - Paro mecánico de cierre adicional para XTILUS		12007428	€ 10,00
	BIOS2 - Centralina per cancelli a 1 o 2 battenti 230Vac. Selezione funzioni tramite display. Con rilevamento ostacoli e autodiagnosi dei dispositivi di sicurezza. <u>Centrale con gestione di un trasmettitore tramite display.</u> - Control unit for 1 or 2 wings gate 230Vac. Functions selection through display. With obstacle detection and self-diagnosis of safety devices. <u>Control unit with managing of a transmitter through the display.</u> - Centrale de commande pour portails avec 1 ou 2 vantaux 230Vac. Sélections des fonctions par écran. Avec détection des obstacles et autodiagnostic des dispositifs de sécurité. <u>Centrale de commande avec gestion d'émetteurs à travers le display.</u> - Cuadro de para cancelas de 1 o 2 hojas 230Vac. Selección funciones a través de un display. Con detección de obstáculos y autodiagnósticos de los dispositivos. <u>Central con gestión de un transmisor a través del display.</u>		12006515	€ 195,00
	BIOS2 ECO - Centralina per cancelli a 1 o 2 battenti 230Vac. Selezione funzioni tramite display. <u>Centrale con gestione di un trasmettitore tramite display.</u> - Control unit for 1 or 2 wings gate 230Vac. Functions selection through display. <u>Control unit with managing of a transmitter through the display.</u> - Centrale de commande pour portails avec 1 ou 2 vantaux 230Vac. Sélections des fonctions par écran. <u>Centrale de commande avec gestion d'émetteurs à travers le display.</u> - Cuadro de mando para cancelas de 1 o 2 hojas 230Vac. Selección funciones a través de un display. <u>Cuadro de mando con gestión de un transmisor a través del display.</u>		12006531	€ 125,00



	BIOS2 24V - Centralina per cancelli a 1 o 2 battenti 24Vdc senza encoder. - Control unit for 1 or 2 wings gate 24Vdc without encoder. - Centrale de commande pour portails avec 1 ou 2 vantaux 24Vdc sans encodeur. - Cuadro de mando para el control de 1 o 2 hojas 24Vdc sin encoder.	12006623	€ 245,00	
	BLUETOOTH - Modulo Bluetooth per centraline BIOS1 e BIOS2. - Bluetooth module for BIOS1 and BIOS2 control units. - Module Bluetooth pour centrales BIOS1 et BIOS2. - Módulo Bluetooth para cuadros de mando BIOS1 y BIOS2.	12006730	€ 95,00	
	R2 - Scheda espansione funzioni per la centralina di comando BIOS 2 ECO o BIOS2 24V. Uscita elettroserratura e luce di cortesia. - Card providing extended functions for the BIOS 2 ECO or BIOS2 24V control unit. Electrical lock and courtesy light outputs. - Carte d'expansion des fonctions pour BIOS2 ECO et BIOS2 24V. Sortie de la serrure électrique et de la lumière de courtoisie. - Tarjeta de expansión de las funciones para el cuadro de mando BIOS2 ECO y BIOS2 24V. Salida cerradura eléctrica y luz de cortesia.	12001703	€ 15,00	
	24CBA - Scheda carica batterie 24V ad innesto con controllo elettronico della carica. - 24V battery charger card with plug-in electronic control of charge level. - Carte chargeur de batterie 24V embrochable avec contrôle électronique de la charge. - Tarjeta enchufable para cargador de baterías 24V con control electrónico de la carga.	Ozionale per BIOS2 24V Optional for BIOS2 24V Optionnel pour BIOS2 24V Opcional para BIOS2 24V	12000780	€ 16,00
	KIT BATTERIE / BATTERIES KIT / KIT BATTERIES / KIT BATERIAS - 2 batterie ricaricabili 12V, 1.3Ah. Cavo 1 mt. - 2 rechargeable batteries 12V, 1.3Ah. 1mt cable. - 2 batteries rechargeable 12V, 1.3Ah. Câble 1mt. - 2 baterías recargable 12V, 1.3Ah. Cable 1 mt.	12000757	€ 67,00	

PLUS L ADVANCE - CATALOGO / CATALOGUE / CATALOGUE / CATÁLOGO PAG. 26



	PLUS L ADVANCE 230Vac - Motoriduttore 230 Vac per cancelli a battente fino a 4,5 metri. <u>Staffe di fissaggio incluse.</u> - 230 Vac gearmotor for wing gates up to 4.5 meters. <u>Mounting brackets included.</u> - Motoréducteur 230 Vac pour portails battants jusqu'à 4.5 mètres. <u>Supports de fixation inclus.</u> - Motorreductor 230 Vac para puertas a hojas de hasta 4.5 metros. <u>Soporte de fijación incluido.</u>	12007435	€ 430,00
	BIOS2 - Centralina per cancelli a 1 o 2 battenti 230Vac. Selezione funzioni tramite display. Con rilevamento ostacoli e autodiagnosi dei dispositivi di sicurezza. <u>Centrale con gestione di un trasmettitore tramite display.</u> - Control unit for 1 or 2 wings gate 230Vac. Functions selection through display. With obstacle detection and self-diagnosis of safety devices. <u>Control unit with managing of a transmitter through the display.</u> - Centrale de commande pour portails avec 1 ou 2 vantaux 230Vac. Sélections des fonctions par écran. Avec détection des obstacles et autodiagnostic des dispositifs de sécurité. <u>Centrale de commande avec gestion d'émetteurs à travers le display.</u> - Cuadro de mando para cancelas de 1 o 2 hojas 230Vac. Selección funciones a través de un display. Con detección de obstáculos y autodiagnósticos de los dispositivos. <u>Central con gestión de un transmisor a través del display.</u>	12006515	€ 195,00





	<p>BIOS2 ECO</p> <ul style="list-style-type: none"> - Centralina per cancelli a 1 o 2 battenti 230Vac. Selezione funzioni tramite display. <u>Centrale con gestione di un trasmettitore tramite display.</u> - Control unit for 1 or 2 wings gate 230Vac. Functions selection through display. <u>Control unit with managing of a transmitter through the display.</u> - Centrale de commande pour portails avec 1 ou 2 vantaux 230Vac. Sélections des fonctions par écran. <u>Centrale de commande avec gestion d'émetteurs à travers le display.</u> - Central para cancelas de 1 o 2 hojas 230Vac. Selección funciones a través de un display. <u>Central con gestión de un transmisor a través del display.</u> 	12006531	€ 125,00
	<p>BLUETOOTH</p> <ul style="list-style-type: none"> - Modulo Bluetooth per centraline BIOS1 e BIOS2. - Bluetooth module for BIOS1 and BIOS2 control units. - Module Bluetooth pour centrales BIOS1 et BIOS2. - Módulo Bluetooth para centrales BIOS1 y BIOS2. 	12006730	€ 95,00
	<p>R2</p> <ul style="list-style-type: none"> - Scheda espansione funzioni per la centralina di comando BIOS 2 ECO o BIOS2 24V. Uscita elettro serratura e luce di cortesia. - Card providing extended functions for the BIOS 2 ECO or BIOS2 24V control unit. Dry contacts to control electrical lock and courtesy light. - Carte d'expansion des fonctions pour BIOS2 ECO et BIOS2 24V. Contacts secs pour la gestion de la serrure électrique et de la lumière de courtoisie. - Tarjeta ampliación funciones para la central de mando BIOS2 ECO y BIOS2 24V. Salida cerradura eléctrica y luz de cortesia. 	12001703	€ 15,00
	<ul style="list-style-type: none"> - Fermo meccanico di chiusura per PLUS L ADVANCE. - Mechanical closing stop for PLUS L ADVANCE. - Fin de course mécanique de fermeture pour PLUS L ADVANCE. - Paro mecánico de cierre para PLUS L ADVANCE. 	64100237	€ 23,00

MINIART R - CATALOGO / CATALOGUE / CATALOGUE / CATÁLOGO PAG. 28

	<p>MINIART R MASTER 24Vdc</p> <ul style="list-style-type: none"> - Motoriduttore 24Vdc per cancelli a battente fino a 2 metri. <u>Staffe di fissaggio incluse.</u> CON CENTRALE BIOS2 24 INCLUSA. BRACCIO ARTICOLATO ESCLUSO - 24Vdc gearmotor for wing gates up to 2 meters. <u>Mounting brackets included.</u> WITH CONTROL UNIT BIOS2 24 INCLUDED. ARTICULATED ARM EXCLUDED - Motoréducteur 24Vdc pour portails battants jusqu'à 2 mètres. <u>Supports de fixation inclus.</u> AVEC CENTRALE BIOS 2 24 INCLUS. BRAS ARTICULÉ EXCLU - Motorreductor 24Vdc para puertas a hojas de hasta 2 metros. <u>Soporte de fijación incluidas.</u> CON CUADRO DE MANDO BIOS2 24 INCLUIDO. BRAZO ARTICULADO EXCLUIDO 	12007414	€ 690,00
	<p>MINIART R SLAVE 24Vdc</p> <ul style="list-style-type: none"> - Motoriduttore 24Vdc per cancelli a battente fino a 2 metri. <u>Staffe di fissaggio incluse.</u> SENZA CENTRALE BIOS2 24. BRACCIO ARTICOLATO ESCLUSO - 24Vdc gearmotor for wing gates up to 2 meters. <u>Mounting brackets included.</u> WITHOUT CONTROL UNIT BIOS2 24. ARTICULATED ARM EXCLUDED - Motoréducteur 24Vdc pour portails battants jusqu'à 2 mètres. <u>Supports de fixation inclus.</u> SANS CENTRALE BIOS 2 24. BRAS ARTICULÉ EXCLU - Motorreductor 24Vdc para puertas a hojas de hasta 2 metros. <u>Soporte de fijación incluidas.</u> SIN CUADRO DE MANDO BIOS2 24. BRAZO ARTICULADO EXCLUIDO 	12007412	€ 450,00
	<p>MINIART R</p> <p>BRACCIO ARTICOLATO. LEVA LUNGA per cancelli con cerniera distante fino a 50 cm dal bordo colonna.</p> <p>ARTICULATED ARM. THE LONG LEVER is suggested for a leaf with a distance up to 50 cm between the hinge of the leaf and the internal side of the pillar.</p> <p>BRAS ARTICULÉ. BRAS LONG pour portails avec l'axe des gonds positionné jusqu'à 50 cm du bord du poteau.</p> <p>BRAZO ARTICULADO. PALANCA LARGA para cancelas con pivote distante hasta 50 cm del borde de la columna.</p>	64000269	€ 160,00
	<p>MINIART R</p> <p>BRACCIO ARTICOLATO. Leva standard</p> <p>ARTICULATED ARM. Standard lever</p> <p>BRAS ARTICULÉ. Bras standard</p> <p>BRAZO ARTICULADO. Palanca estándar</p>	64000268	€ 82,00



MAXIART K - CATALOGO / CATALOGUE / CATALOGUE / CATÁLOGO PAG. 29



	<p>MAXIARTK 230Vac</p> <ul style="list-style-type: none"> - Motoriduttore 230 Vac per cancelli a battente fino a 4 metri. <u>Staffe di fissaggio e braccio articolato inclusi.</u> Centrale di comando esclusa. - 230 Vac gearmotor for wing gates up to 4 meters. <u>Mounting brackets and articulated arm included.</u> Control unit excluded. - Motoréducteur 230 Vac pour portails battants jusqu'à 4 mètres. <u>Supports de fixation et bras articulé inclus.</u> Centrale de commande exclu. - Motorreductor 230 Vac para puertas a hojas de hasta 4 metros. <u>Soporte de fijación y brazo articulado incluidas.</u> Cuadro de mando exluido. 	12007836	€ 455,00
	<p>BIOS2</p> <ul style="list-style-type: none"> - Centralina per cancelli a 1 o 2 battenti 230Vac. Selezione funzioni tramite display. Con rilevamento ostacoli e autodiagnosi dei dispositivi di sicurezza. <u>Centrale con gestione di un trasmettitore tramite display.</u> - Control unit for 1 or 2 wings gate 230Vac. Functions selection through display. With obstacle detection and self-diagnosis of safety devices. <u>Control unit with managing of a transmitter through the display.</u> - Centrale de commande pour portails avec 1 ou 2 vantaux 230Vac. Sélections des fonctions par écran. Avec détection obstacles et autodiagnostic des dispositifs de sécurité. <u>Centrale de commande avec gestion d'émetteurs à travers le display.</u> - Cuadro de mando para cancelas de 1 o 2 hojas 230Vac. Selección funciones a través de un display. Con detección de obstáculos y autodiagnósticos de los dispositivos. <u>Central con gestión de un transmisor a través del display.</u> 	12006515	€ 195,00







	BIOS2 ECO - Centralina per cancelli a 1 o 2 battenti 230Vac. Selezione funzioni tramite display. <u>Centrale con gestione di un trasmettitore tramite display.</u> - Control unit for 1 or 2 wings gate 230Vac. Functions selection through display. <u>Control unit with managing of a transmitter through the display.</u> - Centrale de commande pour portails avec 1 ou 2 vantaux 230Vac. Sélections des fonctions par écran. <u>Centrale de commande avec gestion d'émetteurs à travers le display.</u> - Central para cancelas de 1 o 2 hojas 230Vac. Selección funciones a través de un display. <u>Central con gestión de un transmisor a través del display.</u>	12006531	€ 125,00
	BLUETOOTH - Modulo Bluetooth per centraline BIOS1 e BIOS2. - Bluetooth module for BIOS1 and BIOS2 control units. - Module Bluetooth pour centrales BIOS1 et BIOS2. - Módulo Bluetooth para centrales BIOS1 y BIOS2.	12006730	€ 95,00
	R2 - Scheda espansione funzioni per la centralina di comando BIOS 2 ECO o BIOS2 24V. Uscita elettroserratura e luce di cortesia. - Card providing extended functions for the BIOS 2 ECO or BIOS2 24V control unit. Dry contacts to control electrical lock and courtesy light. - Carte d'expansion des fonctions pour BIOS2 ECO et BIOS2 24V. Contacts secs pour la gestion de la serrure électrique et de la lumière de courtoisie. - Tarjeta ampliación funciones para la central de mando BIOS2 ECO y BIOS2 24V. Salida cerradura eléctrica y luz de cortesia.	12001703	€ 15,00
	- Cordino per sblocco esterno MAXIARTK. - Cable release kit MAXIARTK. - Corde pour déblocage extérieur MAXIARTK. - Dispositivo de desbloqueo exterior MAXIARTK.	64100140	€ 32,00

INT R/XL - CATALOGO / CATALOGUE / CATALOGUE / CATÁLOGO PAG. 30

	INT R/XL 230Vac - Motoriduttore 230 Vac per cancelli a battente fino a 3.5 metri. Con cavo di alimentazione di 6 metri. - 230 Vac gearmotor for wing gates up to 3.5 meters. With 6 meters of power supply cable. - Motorréducteur 230 Vac pour portails battants jusqu'à 3.5 mètres. Avec cable d'alimentation de 6 mètres. - Motorreductor 230 Vac para puertas a hojas de hasta 3.5 metros. Con cable de alimentación largo 6 metros.	12007620	€ 455,00
	INT R/XL2 - 230Vac - Motoriduttore 230 Vac per cancelli a battente fino a 3.5 metri. Con cavo di alimentazione di 9 metri. - 230 Vac gearmotor for wing gates up to 3.5 meters. With 9 meters of power supply cable. - Motorréducteur 230 Vac pour portails battants jusqu'à 3.5 mètres. Avec cable d'alimentation de 9 mètres. - Motorreductor 230 Vac para puertas a hojas de hasta 3.5 metros. Con cable de alimentación largo 9 metros.	12007621	€ 480,00
	INT VS 24Vdc - Motoriduttore 24 Vdc per cancelli a battente fino a 2.5 metri. - 24 Vdc gearmotor for wing gates up to 2.5 meters. - Motorréducteur 24 Vdc pour portails battants jusqu'à 2.5 mètres. - Motorreductor 24 Vdc para puertas a hojas de hasta 2.5 metros.	12007630	€ 400,00
	CAC20 - Cassa di fondazione e coperchio trattato con un processo di verniciatura di alta qualità che assicura un doppio strato protettivo. - Steel foundation box and cover treated with high quality painting process that ensure a double protective layer. - Caisse de fondation et couvercle traité avec un procédé de vernissage de haute qualité, qui assure une double couche de protection. - Caja en fundición y tapa tratado con un procedimiento de pintura de alta calidad que asegura una doble protección.	12007610	€ 185,00
	BIOS2 - Centralina per cancelli a 1 o 2 battenti 230Vac. Selezione funzioni tramite display. Con rilevamento ostacoli e autodiagnosi dei dispositivi di sicurezza. <u>Centrale con gestione di un trasmettitore tramite display.</u> - Control unit for 1 or 2 wings gate 230Vac. Functions selection through display. With obstacle detection and self-diagnosis of safety devices. <u>Control unit with managing of a transmitter through the display.</u> - Centrale de commande pour portails avec 1 ou 2 vantaux 230Vac. Sélections des fonctions par écran. Avec détection obstacles et autodiagnostic des dispositifs de sécurité. <u>Centrale de commande avec gestion d'émetteurs à travers le display.</u> - Central para cancelas de 1 o 2 hojas 230Vac. Selección funciones a través de un display. Con detección de obstáculos y autodiagnósticos de los dispositivos. <u>Central con gestión de un transmisor a través del display.</u>	12006515	€ 195,00
	BIOS2 ECO - Centralina per cancelli a 1 o 2 battenti 230Vac. Selezione funzioni tramite display. <u>Centrale con gestione di un trasmettitore tramite display.</u> - Control unit for 1 or 2 wings gate 230Vac. Functions selection through display. <u>Control unit with managing of a transmitter through the display.</u> - Centrale de commande pour portails avec 1 ou 2 vantaux 230Vac. Sélections des fonctions par écran. <u>Centrale de commande avec gestion d'émetteurs à travers le display.</u> - Central para cancelas de 1 o 2 hojas 230Vac. Selección funciones a través de un display. <u>Central con gestión de un transmisor a través del display.</u>	12006531	€ 125,00





	<p>BIOS2 24V</p> <ul style="list-style-type: none"> - Centralina per cancelli a 1 o 2 battenti 24Vdc con motori interrati. - Control unit for 1 or 2 wings gate 24Vdc with underground motors. - Centrale de commande pour portails avec 1 ou 2 vantaux 24Vdc avec motoréducteur enterré. - Central de mando para el control de 1 o 2 hojas 24Vdc con motores enterrado. 	12006623	€ 245,00
	<p>LEV360/XL</p> <ul style="list-style-type: none"> - Gruppo leve per apertura 360°, solo per INT R/XL. - Group of lever for opening up to 360°, only for INT R/XL. - Groupe lève pour ouverture à 360°, seulement INT R/XL. - Grupo de palancas para aperturas de 360 grados, sólo INT R/XL. 	64000165	€ 130,00
	<p>SBL-LEVS</p> <ul style="list-style-type: none"> - Sistema di sblocco a leva in acciaio. - Steel unlocking system with lever. - Système de déblocage en acier avec levier. - Sistema para el desbloqueo de acero con palanca. 	64000166	€ 90,00

	<p>BEVK4 24Vdc - Barriera stradale 24 Vdc con centralina di comando della serie SCOR.AS incorporata, asta 4m. <u>Necessita di piastra di fissaggio e asta.</u> - 24 Vdc road barrier with SCOR.AS control unit series on board, maximum rod 4m. <u>Backing plate and bar are needed.</u> - Barrière routière 24 Vdc avec centrale de commande de la série SCOR.AS incorporée, tige 4m. <u>Necessite de plaque de fondation et tige.</u> - Barrera de carretera 24 Vdc con central de mando de la serie SCOR.AS incorporada, asta 4m. <u>Necesita la placa de fundición y la asta.</u></p>	<p>12007331</p>	<p>€ 1.310,00</p>
	<p>- Piastra di fissaggio da interrare per BEVK. - Backing plate to be installed underground for BEVK. - Plaque de fixation à enterrer pour BEVK. - Base de fijación a enterrar para BEVK.</p>	<p>64100332</p>	<p>€ 60,00</p>
	<p>- Asta in alluminio rotonda per BEVK4 (2 metri + 2 metri Ø 60mm) - Aluminium circle bar for BEVK4 (2 meters + 2 meters Ø 60mm) - Tige en aluminium ronde pour BEVK4 (2 mètres + 2 mètres Ø 60mm) - Asta de aluminio rotonda por BEVK4 (2 metros + 2 metros Ø 60mm)</p>	<p>64100345</p>	<p>€ 270,00</p>
	<p>24CBA - Scheda carica batterie 24V ad innesto con controllo elettronico della carica. - 24V battery charger card with guided coupling guide and electronic control of charge level. - Carte chargeur de batterie 24V embrochable avec contrôle électronique de la charge. - Tarjeta enchufable para cargador de baterías 24V con control electrónico de la carga.</p>	<p>12000780</p>	<p>€ 16,00</p>



	BATTERIA / BATTERY / BATTERIE / BATERÍA - Batteria ricaricabile 12V, 7.2Ah. Dim. (mm) W x D x H = 150 X 65 X 95. - Rechargeable battery 12V, 7.2Ah. Dim. (mm) W x D x H = 150 X 65 X 95. - Batteries rechargeable 12V, 7.2Ah. Dim. (mm) W x D x H = 150 X 65 X 95. - Batería recargable 12V, 7.2Ah. Dim. (mm) W x D x H = 150 X 65 X 95.	61400056	€ 62,00
	- Paletto di supporto fisso. - Fixed support stake. - Petit pieu de support fixe. - Poste de apoyo fijo.	64100338	€ 70,00
	- Paletto di supporto mobile, pendulo. - Movable support stake, hanging. - Petit pieu de support mobile. - Poste de apoyo móvil, péndular.	64100339	€ 116,00
	- Gomma antiurto completa di accessori per BEVK4 (4 metri). - Rubber shockproof with accessories for BEVK4 (4 meters). - Gomme antichoc barre avec accessoires pour BEVK4 (4 mètres). - Goma contra golpe barra con accesorios para BEVK4 (4 metros).	64100331	€ 90,00
	A1H-U Rilevatore di presenza veicoli, amplificatore per spire magnetiche a 1 relé. Vehicle presence detector amplifier for magnetic loops with 1 relay. Détecteur de présence véhicule, amplificateur pour spire magnétique à 1 relais. Detector de presencia de vehiculos, amplificador para espiras magnéticas de 1 relé.	12000820	€ 178,00
	KIT BATTERIE / BATTERIES KIT / KIT BATTERIES / KIT BATERIAS - 2 batterie ricaricabili 12V, 1.3Ah. Cavo 1 mt. - 2 rechargeable batteries 12V, 1.3Ah. 1mt cable. - 2 batteries rechargeable 12V, 1.3Ah. Câble 1mt. - 2 baterías recargable 12V, 1.3Ah. Cable 1 mt.	12000757	€ 67,00









BRT - CATALOGO / CATALOGUE / CATALOGUE / CATÁLOGO PAG. 33

	BRT SIMPLE 230Vac - Barriera stradale 230Vac con centralina di comando BIOS1 BRT incorporata. Per aste fino a 6 metri e tempo di apertura da 2.5 a 6 secondi. <u>Piastra di fissaggio, asta e mozzo esclusi.</u> - 230Vac road barrier with BIOS1 BRT control unit on-board. For bars up to 6 meters and opening time from 2.5 to 6 seconds. <u>Backing plate, bar and clamp hub excluded.</u> - Barrière routière 230Vac avec centrale de commande BIOS1 BRT incorporée. Pour des tige jusqu'à 6 mètres et temps d'ouverture de 2.5 à 6 secondes. <u>Plaque de fondation, tige et moyeu de fixation exclus.</u> - Barrera de carretera 230Vac con central de mando BIOS1 BRT incorporada. Para asta de hasta 6 metros y tiempo de apertura de 2.5 a 6 segundos. <u>Placa de fundición, la asta y buje de fijación excluidos.</u>	12007351	€ 1.650,00
---	--	----------	------------



	<ul style="list-style-type: none"> - Piastra di fissaggio da interrare per BRT. - Backing plate to be installed underground for BRT. - Plaque de fixation à enterrer pour BRT. - Base de fijación a enterrar para BRT. 	64100240	€ 118,00
	<ul style="list-style-type: none"> - Mozzo per aste Ø 60 e Ø 80. - Clamp hub for bars Ø 60 and Ø 80. - Moyeu de fixation pour lisses Ø 60 et Ø 80. - Bujes de fijación para asta Ø 60 y Ø 80. 	Ø 60 64100236	€ 140,00
	<ul style="list-style-type: none"> - Paletto di supporto a forcella compatibile con tutte le aste. - Fork support stake, compatible with all bars. - Petit pieu de support à fourche compatible avec toutes les tiges. - Poste de soporte en forma de horquilla compatible con todas las astas. 	64100245	€ 155,00
	ASTA TELESCOPICA / TELESCOPIC BAR / TIGE TÉLESCOPIQUE / ASTA TELESCÓPICA: <ul style="list-style-type: none"> - 3 mt. Ø 60. - 4 mt. Ø 60. - 5 mt. Ø 80. - 6 mt. Ø 80: disponibile solo su richiesta / available only on demand disponible seulement sur demande / disponibles sólo bajo pedido. 	64100266 64100267 64100268 64100269	€ 155,00 € 200,00 € 295,00 € 340,00
	ASTE SNODATA / ARTICULATED BARS / TIGE ARTICULÉE / ASTA ARTICULADA <ul style="list-style-type: none"> - 3 mt. Ø 80. - 4 mt. Ø 80. - 5 mt. Ø 80. <p><u>Solo per BRT SIMPLE - Only for BRT SIMPLE - Seulement pour BRT SIMPLE - Sólo para BRT SIMPLE.</u></p>	64100263 64100264 64100265	€ 875,00 € 965,00 € 1.055,00

TECNO CAT - CATALOGO / CATALOGUE / CATALOGUE / CATÁLOGO PAG. 34



	TECNO CAT MASTER 24Vdc <ul style="list-style-type: none"> - Barriera a catena 24Vdc con centralina di comando ACTION incorporata. Per passaggi fino a 20 metri. - 24Vdc chain barrier with ACTION control unit on-board. For passages up to 20 meters. - Barrière à chaîne 24Vdc avec centrale de commande ACTION incorporée. Pour des passages jusqu'à 20 mètres. - Barrera con cadena 24Vdc con central de mando ACTION incorporada. Para pasajes de hasta 20 metros. 	12007375	€ 850,00
	TECNO CAT SLAVE 24Vdc <ul style="list-style-type: none"> - Barriera a catena 24Vdc. Per passaggi fino a 20 metri. - 24Vdc chain barrier. For passages up to 20 meters. - Barrière à chaîne 24Vdc. Pour des passages jusqu'à 20 mètres. - Barrera con cadena 24Vdc. Para pasajes de hasta 20 metros. 	12007380	€ 615,00
	24CBA <ul style="list-style-type: none"> - Scheda carica batterie 24V ad innesto con controllo elettronico della carica. - 24V battery charger card with guided coupling guide and electronic control of charge level. - Carte chargeur de batterie 24V embrochable avec contrôle électronique de la charge. - Tarjeta enchufable para cargador de baterías 24V con control electrónico de la carga. 	12000780	€ 16,00







	<p>BATTERIA / BATTERY / BATTERIE / BATERÍA</p> <ul style="list-style-type: none"> - Batteria ricaricabile 12V, 7.2Ah. Dim. (mm) W x D x H = 150 X 65 X 95. - Rechargeable battery 12V, 7.2Ah. Dim. (mm) W x D x H = 150 X 65 X 95. - Batteries rechargeable 12V, 7.2Ah. Dim. (mm) W x D x H = 150 X 65 X 95. - Batería recargable 12V, 7.2Ah. Dim. (mm) W x D x H = 150 X 65 X 95. 	61400056	€ 62,00
	<ul style="list-style-type: none"> - Catena d'acciaio bicolore bianco / rosso - White / red steel chain. - Chaîne en acier bicolore blanche / rouge. - Cadena de acero bicolor blanco / rojo. 	64000404	€ 11,50/mt
	<ul style="list-style-type: none"> - Catena in acciaio zincato. - Galvanized steel chain. - Chaîne en acier galvanisé. - Cadena de acero galvanizado. 	64000405	€ 9,50 / m
	<ul style="list-style-type: none"> - Giunto di rottura. - Safety breaking joint. - Joint de rupture. - Junta de ruptura. 	12007395	€ 23,00
	<ul style="list-style-type: none"> - Guida da incasso in lamiera zincata L=2 metri. - Galvanized sheet metal rail for underground installation L=2 meters. - Guide à terre en tôle galvanisé L=2 mètres. - Guía cadena en chapa galvanizada de enterrar L=2 metros. 	64000409	€ 25,00 / 2 m
	<ul style="list-style-type: none"> - Vite TCEI M8x25 INOX tornita. - Turned TCEI M8x25 INOX screw. - Vis tournée TCEI M8x25 INOX. - Tornillo TCEI M8x25 INOX torneado. 	61700446	€ 4,00
	<ul style="list-style-type: none"> - Maglia di giunzione in acciaio INOX Ø 6mm. - Stainless steel junction link Ø 6 mm. - Anneau de jonction en acier INOX Ø 6mm. - Eslavón de unión en acero INOX Ø 6mm. 	64000407	€ 11,00
	<p>KIT BATTERIE / BATTERIES KIT / KIT BATTERIES / KIT BATERIAS</p> <ul style="list-style-type: none"> - 2 batterie ricaricabili 12V, 1.3Ah. Cavo 1 mt. - 2 rechargeable batteries 12V, 1.3Ah. 1mt cable. - 2 batteries rechargeable 12V, 1.3Ah. Câble 1mt. - 2 baterias recargable 12V, 1.3Ah. Cable 1 mt. 	12000757	€ 67,00







	<p>SER UNI 170</p> <ul style="list-style-type: none"> - Operatore per serrande avvolgibili bilanciate con molle. Fornito con coppia semigusci Ø 48/60 (cod. 64100601) e adattatore puleggia portamolle (cod. 64100600). Con elettrofreno. - Gearmotor for spring balanced roll-up shutters. Supply with a couple of half shells Ø 48/60 (cod. 64100601), and pulley-springs adapter (cod. 64100600). With electrical brake. - Opérateur pour rideaux enroulables équilibré à ressorts. Fourni avec paire de demi-coques Ø 48/60 (cod. 64100601), et adaptateur poulie porte-ressorts (cod. 64100600). Avec électro frein. - Motor para las persianas enrollables equilibradas con muelles. Suministrado con pareja de capas semicirculares Ø 48/60 (cod. 64100601), y adaptador para polea portaresorte (cod. 64100600). Con electrofreno. 		64000670	€ 247,00
	<p>SER 22</p> <ul style="list-style-type: none"> - SER 22 230V Operatore per serrande avvolgibili bilanciate con molle. Completo di elettrofreno con cavo, guaina e pomello di sblocco. - SER 22 230V Gearmotor for spring balanced roll-up shutters. Including electronic brake with cable, case and releasing knob. - SER 22 230V Opérateur pour rideaux enroulables équilibré à ressorts. Complète de frein électrique avec câble, gaine et pommeau de déblocage. - SER 22 230V perador para persianas enrollables equilibradas con muelles. Con electrofreno completo con cable, revestimiento y pomo de desbloqueo. 		64000136	€ 239,00
	<p>AV</p> <ul style="list-style-type: none"> - Centralina per serrande 230Vac in box. - Control unit for roll-up shutters 230Vac. - Centrale de commande pour stores enroulables 230Vac. - Central para persianas 230Vac. 		12006557	€ 78,00
	<p>BAX900</p> <ul style="list-style-type: none"> - Centralina per serrande 230Vac in box. Programmazione del tempo di lavoro da trimmer. - Control unit for roll-up shutters 230Vac in box. Easy setting of working time by trimmer. - Centrale de commande pour stores enroulables 230Vac en box. Programmation facile du temps de travail par trimmer. - Central para persianas 230Vac en caja. Fácil programación del tiempo de trabajo por trimmer. 		12006704	€ 80,00
	<p>BAX900L</p> <ul style="list-style-type: none"> - Centralina per serrande 230Vac in box con luce di cortesia. Programmazione del tempo di lavoro da trimmer ed autodiagnosi dei dispositivi di sicurezza. - Control unit for roll-up shutters 230Vac in box with courtesy light. Easy setting of working time by trimmer and self-diagnosis of safety devices. - Centrale de commande pour stores enroulables 230Vac dans un boîtier avec lumière de courtoisie. Programmation facile du temps de travail par trimmer et autodiagnostic des dispositifs de sécurité. - Central para persianas 230Vac en caja con luz de cortesia. Fácil programación del tiempo de trabajo por trimmer y autodiagnóstico de los dispositivos de seguridad. 		12006705	€ 100,00
	<p>AM900ECO</p> <ul style="list-style-type: none"> - Centralina per serrande 230 Vac fino a 1000W. È prevista un'uscita per la luce di cortesia. Tempo di lavoro programmabile - Control unit for rolling shutters 230Vac up to 1000W. It is equipped with a courtesy light output. Programmable working time - Centrale de commande pour stores enroulables 230Vac jusqu'à 1000W. Elle est équipée d'une sortie pour la lumière de courtoisie... Temps de travail programmable. - Central para persianas 230Vac hasta 1000W. Es prevista una salida para la luz de cortesia. Tiempo de trabajo programable 		12006702	€ 65,00
	<p>BLD: Box in alluminio da esterno con pulsante e leva di sblocco. BLD: Aluminium box for external installation with button and releasing lever. BLD: Box en aluminium d'extérieur avec bouton et levier de déblocage. BLD: Caja de aluminio para exteriores con botón y palanca de desbloqueo.</p> <p>CA-BLD: Cassetta per fissaggio esterno BLD. CA-BLD: Box for external installation of BLD. CA-BLD: boîte pour fixation externe BLD. CA-BLD: Caja por fijado externo BLD.</p>		BLD 64100015	€ 70,00
			CA-BLD 64100016	€ 12,00

	<p>BLDR: Box in alluminio da esterno con pulsante e leva di sblocco. BLDR: Aluminium box for external installation with button and releasing lever. BLDR: Box en aluminium d'extérieur avec bouton et levier de déblocage. BLDR: Caja de aluminio para exteriores con botón y palanca de desbloqueo.</p> <p>BLDR/I: Box in alluminio da incasso con pulsante e leva di sblocco. BLDR/I: Aluminium box for built-in installation with button and releasing lever. BLDR/I: Box en aluminium à muré avec bouton et levier de déblocage. BLDR/I: Caja de aluminio para empotrar con botón y palanca de desbloqueo.</p>	<p>BLDR 64100248</p> <p>BLDR/I 64100252</p>	<p>€ 78,00</p> <p>€ 80,00</p>
	<p>EL_FRK</p> <ul style="list-style-type: none"> - Elettrofreno completo di cavo, guaina e pomello di sblocco per SER UNI 170. - Electronic brake including cable, case and releasing knob for SER UNI 170. - Frein électrique complet de câble, gaine et pommeau de déblocage SER UNI 170. - Elettrofreno completo con cable, revestimiento y pomo de desbloqueo SER UNI 170. 	<p>64100229</p>	<p>€ 37,00</p>
	<p>PLK</p> <ul style="list-style-type: none"> - Selettore a chiave da esterno in alluminio presso fuso; 2 contatti micro. - External die-cast aluminium key selector; 2 micro-switch. - Sélecteur à clé d'extérieur en aluminium moulé sous pression; 2 contacts micro. - Selector de llave para exterior en fundición de aluminio; 2 microcontactos. 	<p>64100009</p>	<p>€ 33,00</p>



WIFI-BAND @ 868 - CATALOGO / CATALOGUE / CATALOGUE / CATÁLOGO PAG. 38-39



	<p>T.CO.0</p> <ul style="list-style-type: none"> - Sistema radio per coste meccaniche e 8,2KΩ, solo parte mobile. - Radio system for mechanical and 8,2KΩ safety edges, only movable part. - Système radio pour barres palpeuses mécaniques et 8,2KΩ, seulement dispositif mobile. - Sistema radio para bordes mecánicos y 8,2KΩ, sólo parte móvil. 	<p>12006778</p>	<p>€ 70,00</p>
	<p>R.CO.0</p> <ul style="list-style-type: none"> - Sistema radio per coste meccaniche e 8,2KΩ, solo parte fissa. - Radio system for mechanical and 8,2KΩ safety edges, only fix part. - Système radio pour barres palpeuses mécaniques et 8,2KΩ, seulement dispositif fixe. - Sistema radio para bordes mecánicos y 8,2KΩ, sólo parte fija. 	<p>12006771</p>	<p>€ 75,00</p>
	<p>R.CO.0: box stagno / watertight box / boîtier étanche / en caja estanca</p> <ul style="list-style-type: none"> - Sistema radio per coste meccaniche e 8,2KΩ, solo parte fissa. - Radio system for mechanical and 8,2KΩ safety edges, only fix part. - Système radio pour barres palpeuses mécaniques et 8,2KΩ, seulement dispositif fixe. - Sistema radio para bordes mecánicos y 8,2KΩ, sólo parte fija. 	<p>12006772</p>	<p>€ 95,00</p>

	<p>T.CO.0 Double</p> <ul style="list-style-type: none"> - Sistema radio per coste meccaniche e 8,2KΩ, solo parte mobile. - Radio system for mechanical and 8,2KΩ safety edges, only movable part. - Système radio pour barres palpeuses mécaniques et 8,2KΩ, seulement dispositif mobile. - Sistema radio para bordes mecánicos y 8,2KΩ, sólo parte móvil. 	12006769	€ 72,00
	<p>R.CO.0 Double</p> <ul style="list-style-type: none"> - Sistema radio per coste meccaniche e 8,2KΩ, solo parte fissa. - Radio system for mechanical and 8,2KΩ safety edges, only fix part. - Système radio pour barres palpeuses mécaniques et 8,2KΩ, seulement dispositif fixe. - Sistema radio para bordes mecánicos y 8,2KΩ, sólo parte fija. 	12006767	€ 80,00
	<p>R.CO.0 Double: box stagno / watertight box / boîtier étanche / en caja estanca</p> <ul style="list-style-type: none"> - Sistema radio per coste meccaniche e 8,2KΩ, solo parte fissa. - Radio system for mechanical and 8,2KΩ safety edges, only fix part. - Système radio pour barres palpeuses mécaniques et 8,2KΩ, seulement dispositif fixe. - Sistema radio para bordes mecánicos y 8,2KΩ, sólo parte fija. 	12006766	€ 98,00
	<p>KIT T.CO.0-R.CO.0</p> <ul style="list-style-type: none"> - Sistema radio per coste meccaniche e 8,2KΩ. - Radio system for mechanical and 8,2KΩ safety edges. - Système radio pour barres palpeuses mécaniques et 8,2KΩ. - Sistema radio para bordes mecánicos y 8,2KΩ. 	12006777	€ 165,00
	<p>KIT T.CO.0-R.CO.0 Double</p> <ul style="list-style-type: none"> - Sistema radio per coste meccaniche e 8,2KΩ. - Radio system for mechanical and 8,2KΩ safety edges. - Système radio pour barres palpeuses mécaniques et 8,2KΩ. - Sistema radio para bordes mecánicos y 8,2KΩ. 	12006774	€ 170,00
	<ul style="list-style-type: none"> - R.CO.0 con connettore molex per centralina BAX900L. - R.CO.0 with molex for BAX900L control unit. - R.CO.0 avec connecteur Molex pour la centrale de commande BAX900L. - R.CO.0 con conector molex para central BAX900L. 	12006773	€ 70,00
	<p>BS01-C15</p> <ul style="list-style-type: none"> - Coste meccaniche alto profilo (70 mm) colore giallo nero per cancelli: Costa meccanica assemblata per cancelli L=1.5 metri. - Yellow black high profile (70 mm) mechanical safety edges for gates: assembled mechanical safety edge for gates L=1.5 meters. - Barre palpeuse mécanique couleur jaune noir haut profil (70 mm) pour portails: barre palpeuse assemblée pour portail L=1.5 mètres. - Bordes mecánicos con perfil alto (70mm) color amarillo negro para cancelas: borde mecánico ensamblado para cancelas L=1.5 metros. 	64100020	€ 66,00
	<p>BS01-C20</p> <ul style="list-style-type: none"> - Coste meccaniche alto profilo (70 mm) colore giallo nero per cancelli: Costa meccanica assemblata per cancelli L=2 metri. - Yellow black high profile (70 mm) mechanical safety edges for gates: assembled mechanical safety edge for gates L=2 meters. - Barre palpeuse mécanique couleur jaune noir haut profil (70 mm) pour portails: barre palpeuse assemblée pour portail L=2 mètres. - Bordes mecánicos con perfil alto (70mm) color amarillo negro para cancelas: borde mecánico ensamblado para cancelas L=2 metros. 	64100021	€ 78,00
	<p>BS01-C25</p> <ul style="list-style-type: none"> - Coste meccaniche alto profilo (70 mm) colore giallo nero per cancelli: Costa meccanica assemblata per cancelli L=2.5 metri. - Yellow black high profile (70 mm) mechanical safety edges for gates: assembled mechanical safety edge for gates L=2.5 meters. - Barre palpeuse mécanique couleur jaune noir haut profil (70 mm) pour portails: barre palpeuse assemblée pour portail L=2.5 mètres. - Bordes mecánicos con perfil alto (70mm) color amarillo negro para cancelas: borde mecánico ensamblado para cancelas L=2.5 metros. 	64100221	€ 90,00



	<p>CP30</p> <ul style="list-style-type: none"> - Coste meccaniche basso profilo (30 mm) colore nero per basculante: confezione con 2 bobine di profilo da 20 metri cadauna più 20 pz di barra di alluminio, L=2 metri cadauna. - Black low profile (30 mm) mechanical safety edges for bascule door: set with 2 profile spools each 20 meters and 20 pieces aluminium bar each L=2 meters. - Barre palpeuse mécanique couleur noir bas profile (30 mm) pour basculantes: paquet de 2 bobines de 20 mètres de profil chacune plus 20 pièces de barre d'aluminium de 2 mètres chacune. - Borde mecánicos con perfil bajo (30mm) color negro para basculantes: confección con 2 bobinas de perfil de 20 metros cada una y más 20 piezas de barra de aluminio, L=2 metros cada una. 	64100027	€ 656,00 / conf
	<p>CP30-K40</p> <ul style="list-style-type: none"> - Coste meccaniche basso profilo (30 mm) colore nero per basculante: kit di accessori per montaggio di una costa da 4 metri. - Black low profile (30 mm) mechanical safety edges for bascule door: assembling kit for a single 4 meters safety edge. - Barre palpeuse mécanique couleur noir bas profile (30 mm) pour basculantes: kit d'accessoires pour le montage d'une barre palpeuse de 4 mètres. - Borde mecánicos con perfil bajo (30mm) color negro para basculantes: kit de accesorios para el montaje de un borde de 4 metros. 	64100028	€ 47,00
	<p>CP30-K60</p> <ul style="list-style-type: none"> - Coste meccaniche basso profilo (30 mm) colore nero per basculante: kit di accessori per montaggio di una costa da 6 metri. - Black low profile (30 mm) mechanical safety edges for bascule door: assembling kit for a single 6 meters safety edge. - Barre palpeuse mécanique couleur noir bas profile (30 mm) pour basculantes: kit d'accessoires pour le montage d'une barre palpeuse de 6 mètres. - Borde mecánicos con perfil bajo (30mm) color negro para basculantes: kit de accesorios para el montaje de un borde de 6 metros. 	64100029	€ 52,00
	<p>CP30-C25</p> <ul style="list-style-type: none"> - Coste meccaniche basso profilo (30 mm) colore nero per basculante: costa meccanica assemblata per basculante, L 2.5 metri. - Black low profile (30 mm) mechanical safety edges for bascule door: assembled mechanical safety edge for bascule door, L 2.5 meters. - Barre palpeuse mécanique couleur noir bas profile (30 mm) pour basculantes: barre palpeuse assemblée pour basculante, L 2.5 mètres. - Borde mecánicos con perfil bajo (30mm) color negro para basculantes: borde mecánico ensamblado para basculantes, L 2.5 metros. 	64100023	€ 90,00
	<p>CP30-C30</p> <ul style="list-style-type: none"> - Coste meccaniche basso profilo (30 mm) colore nero per basculante: costa meccanica assemblata per basculante, L 3 metri. - Black low profile (30 mm) mechanical safety edges for bascule door: assembled mechanical safety edge for bascule door, L 3 meters. - Barre palpeuse mécanique couleur noir bas profile (30 mm) pour basculantes: barre palpeuse assemblée pour basculante, L 3 mètres. - Borde mecánicos con perfil bajo (30mm) color negro para basculantes: borde mecánico ensamblado para basculantes, L 3 metros. 	64100022	€ 107,00
	<p>CP30-C35</p> <ul style="list-style-type: none"> - Coste meccaniche basso profilo (30 mm) colore nero per basculante: costa meccanica assemblata per basculante, L 3.5 metri. - Black low profile (30 mm) mechanical safety edges for bascule door: assembled mechanical safety edge for bascule door, L 3.5 meters. - Barre palpeuse mécanique couleur noir bas profile (30 mm) pour basculantes: barre palpeuse assemblée pour basculante, L 3.5 mètres. - Borde mecánicos con perfil bajo (30mm) color negro para basculantes: borde mecánico ensamblado para basculantes, L 3.5 metros. 	64100024	€ 120,00

CENTRALINE PER 1 MOTORE 230V / CONTROL UNITS FOR 1 GEARMOTOR 230V
CENTRALES DE COMMANDE POUR 1 MOTEUR 230V / CENTRALES DE MANDO PARA 1 MOTOR 230V

	<p>AV / AV1</p> <ul style="list-style-type: none"> - Centralina per serrande e scorrevoli 230Vac in box. Programmazione del tempo di lavoro da trimmer. AV1 predisposta per regolatore di coppia e scheda R2 aggiuntiva. - Control unit for roll-up shutters and sliding gates 230Vac in box. Setting of working time by trimmer. AV1 preset for torque adjuster and additional R2 card. - Centrale de commande pour stores enroulables et portails coulissants 230Vac en box. Programmation du temps de travail par trimmer. AV1 prédisposée pour régulateur de couple et carte R2 additionnel. - Central para persianas y cancelas correderas 230Vac en caja. Programación del tiempo de trabajo por trimmer. AV1 predispuesta para regulador de par y tarjeta R2 adicional. 		<p>AV 12006557</p> <p>AV1 12006554</p>	<p>€ 78,00</p> <p>€ 86,00</p>
	<p>ERMES2</p> <ul style="list-style-type: none"> - Centralina per scorrevoli e basculanti 230Vac inseribile a bordo del motore. Selezione funzioni tramite dip switch. - Control unit for bascule and sliding gates 230Vac. It can be directly installed on-board the motor. Function selection by dip switch. - Centrale de commande pour portails coulissants et basculant 230Vac insérable à bord du moteur. Sélection fonctionne par dip-switch. - Central de mando para cancelas correderas y puertas basculantes 230Vac a bordo del motor. Selección de funciones mediante dip switch. 		<p>ERMES2 12006711</p> <p>ERMES2 + BOX 12006713</p>	<p>€ 110,00</p> <p>€ 130,00</p>
	<p>BAX900</p> <ul style="list-style-type: none"> - Centralina per serrande 230Vac in box. Programmazione del tempo di lavoro da trimmer. - Control unit for roll-up shutters 230Vac in box. Easy setting of working time by trimmer. - Centrale de commande pour stores enroulables 230Vac en box. Programmation facile du temps de travail par trimmer. - Central para persianas 230Vac en caja. Fácil programación del tiempo de trabajo por trimmer. 		<p>12006704</p>	<p>€ 80,00</p>
	<p>BAX900L</p> <ul style="list-style-type: none"> - Centralina per serrande 230Vac in box con luce di cortesia. Programmazione del tempo di lavoro da trimmer ed autodiagnosi dei dispositivi di sicurezza. - Control unit for roll-up shutters 230Vac in box with courtesy light. Easy setting of working time by trimmer and self-diagnosis of safety devices. - Centrale de commande pour stores enroulables 230Vac dans un boîtier avec lumière de courtoisie. Programmation facile du temps de travail par trimmer et autodiagnostic des dispositifs de sécurité. - Central para persianas 230Vac en caja con luz de cortesia. Fácil programación del tiempo de trabajo por trimmer y autodiagnóstico de los dispositivos de seguridad. 		<p>12006705</p>	<p>€ 100,00</p>

	<p>BIOS1</p> <ul style="list-style-type: none"> - Centralina per cancelli scorrevoli 230Vac. Selezione funzioni tramite display. Con rilevamento ostacoli e autodiagnosi dei dispositivi di sicurezza. <u>Centrale con gestione di un trasmettitore tramite display. Senza trasformatore TCT BIOS1.</u> - Control unit for sliding gates 230Vac. Functions selection through display. With obstacle detection and self-diagnosis of safety devices. <u>Control unit with managing of a transmitter through the display. Without TCT BIOS1 transformer.</u> - Centrale de commande pour portails coulissants 230Vac. Sélections des fonctions par écran. Avec détection obstacles et autodiagnostic des dispositifs de sécurité. <u>Centrale de commande avec gestion d'émetteurs à travers le display. Sans transformateur TCT BIOS1.</u> - Central para cancelas correderas 230Vac. Selección funciones a través de un display. Con detección de obstáculos y autodiagnósticos de los dispositivos. <u>Central con gestión de un transmisor a través del display. Sin transformador TCT BIOS1.</u> 	<p>BIOS1 12006721</p>	<p>€ 90,00</p>
	<p>BIOS1 24</p> <ul style="list-style-type: none"> - Centralina per cancelli scorrevoli 24Vdc. Selezione funzioni tramite display. Con rilevamento ostacoli e autodiagnosi dei dispositivi di sicurezza. <u>Centrale con gestione di un trasmettitore tramite display.</u> - Control unit for sliding gates 24Vdc. Functions selection through display. With obstacle detection and self-diagnosis of safety devices. <u>Control unit with managing of a transmitter through the display.</u> - Centrale de commande pour portails coulissants 24Vdc. Sélections des fonctions par écran. Avec détection obstacles et autodiagnostic des dispositifs de sécurité. <u>Centrale de commande avec gestion d'émetteurs à travers le display.</u> - Central para cancelas correderas 24Vdc. Selección funciones a través de un display. Con detección de obstáculos y autodiagnósticos de los dispositivos. <u>Central con gestión de un transmisor a través del display.</u> 	<p>BIOS1 24 12006628</p>	<p>€ 115,00</p>
		<p>TCT BIOS1 60550027</p>	<p>€ 30,00</p>
		<p>TCT BIOS1 24 60550048</p>	<p>€ 42,00</p>





CENTRALINE PER 2 MOTORI 230V / CONTROL UNITS FOR 2 GEARMOTORS 230V
CENTRALES DE COMMANDE POUR 2 MOTEURS 230V / CENTRALES DE MANDO PARA 2 MOTORES 230V

	<p>BIOS2</p> <ul style="list-style-type: none"> - Centralina per cancelli a 1 o 2 battenti 230Vac. Selezione funzioni tramite display. Con rilevamento ostacoli e autodiagnosi dei dispositivi di sicurezza. <u>Centrale con gestione di un trasmettitore tramite display.</u> - Control unit for 1 or 2 wings gate 230Vac. Functions selection through display. With obstacle detection and self-diagnosis of safety devices. <u>Control unit with managing of a transmitter through the display.</u> - Centrale de commande pour portails avec 1 ou 2 vantaux 230Vac. Sélections des fonctions par écran. Avec détection obstacles et autodiagnostic des dispositifs de sécurité. <u>Centrale de commande avec gestion d'émetteurs à travers le display.</u> - Central para cancelas de 1 o 2 hojas 230Vac. Selección funciones a través de un display. Con detección de obstáculos y autodiagnósticos de los dispositivos. <u>Central con gestión de un transmisor a través del display.</u> 	<p>12006515</p>	<p>€ 195,00</p>
	<p>BIOS2 ECO</p> <ul style="list-style-type: none"> - Centralina per cancelli a 1 o 2 battenti 230Vac. Selezione funzioni tramite display. <u>Centrale con gestione di un trasmettitore tramite display.</u> - Control unit for 1 or 2 wings gate 230Vac. Functions selection through display. <u>Control unit with managing of a transmitter through the display.</u> - Centrale de commande pour portails avec 1 ou 2 vantaux 230Vac. Sélections des fonctions par écran. <u>Centrale de commande avec gestion d'émetteurs à travers le display.</u> - Central para cancelas de 1 o 2 hojas 230Vac. Selección funciones a través de un display. <u>Central con gestión de un transmisor a través del display.</u> 	<p>12006531</p>	<p>€ 125,00</p>

CENTRALINE PER 1 MOTORE 24V / CONTROL UNITS FOR 1 GEARMOTOR 24V
CENTRALES DE COMMANDE POUR 1 MOTEUR 24V / CENTRALES DE MANDO PARA 1 MOTOR 24V

	<p>ACTION TECNO CAT</p> <ul style="list-style-type: none"> - Centralina per motori 24Vdc con encoder. - Control unit for 24Vdc motors with encoder. - Centrale pour moteur 24Vdc avec encoder. - Central de mando para motores 24Vdc con encoder. <p>ACTION per TECNO CAT / for TECNO CAT / pour TECNO CAT / para TECNO CAT</p>	<p>12006649</p>	<p>€ 95,00</p>
--	---	-----------------	----------------



CENTRALINE PER MOTORI TRIFASE / CONTROL UNITS FOR THREE-PHASE GEARMOTORS CENTRALES DE COMMANDE POUR MOTEUR TRIPHASÉ / CENTRALES DE MANDO PARA MOTOR TRIFÁSICO









	<p>CT3IND</p> <ul style="list-style-type: none"> - Centralina di comando per il controllo e l'azionamento, mediante telerruptori, di automazioni industriali a un motore trifase 50Hz 400Vac 1.5KW max oppure monofase 230Vac 50Hz 800W max. Con box semplice (BOX) o box con pulsanti apre, stop e chiude (BOX_B). - Control board for the operating and controlling, through contactors, of industrial automations equipped with one three-phase motor 400Vac 50Hz 1.5KW max or single phase 230Vac 50Hz 800W max. With simple box (BOX) or box with open, stop and close buttons (BOX_B). - Centrale de commande pour le contrôle et l'accionnement, par télérupteurs, d'automations industrielles à un moteur triphasé 400 Vac 50Hz 1.5KW max ou monophasé 230 Vac 50Hz 800W max. Avec boîtier simple (BOX) ou boîtier avec boutons ouvre, stop et ferme (BOX_B). - Central para el control y el accionamiento, mediante telerruptores, de automatismos industriales de un motor trifasico 400 Vac 50Hz 1.5KW max, o bien monofasico 230 Vac 50Hz 800W max. Con caja simple (BOX) o caja con tecla abre, stop y cierra (BOX_B). 	<p>CT3IND+BOX 12001107</p> <p>CT3IND+BOX_B 12001106</p>	<p>€ 378,00</p> <p>€ 422,00</p>
	<p>CTINVERTER TRIFASE NEW</p> <ul style="list-style-type: none"> - Quadro di comando per il controllo e l'azionamento di un motore trifase 230Vac 50Hz 1,5KW (collegato a triangolo Δ). Con box semplice (BOX) o box con pulsanti apre, stop e chiude (BOX_B). <u>Ricevitore B.RO22W LED 2ch opzionale.</u> - Control board for the operating and controlling of a three-phase motor 230Vac 50Hz 1,5KW (delta connected Δ). With simple box (BOX) or box with open, stop and close buttons (BOX_B). <u>Optional B.RO22W LED 2ch receiver.</u> - Centrale de commande pour le contrôle et l'accionnement, d'automations industrielles à un moteur triphasé 230Vac 50Hz 1,5KW (couplé en triangle Δ). Avec boîtier simple (BOX) ou boîtier avec boutons ouvre, stop et ferme (BOX_B). <u>Récepteur B.RO22W LED 2ch optionnel.</u> - Cuadro de mando para el control y el accionamiento de automatismos industriales de un motor trifasico 230Vac 50Hz 1,5KW (conectado a triángulo Δ). Con caja simple (BOX) o caja con tecla abre, stop y cierra (BOX_B). <u>Receptor B.RO22W LED 2ch opcional.</u> 	<p>BOX 12006563</p> <p>BOX_B 12006568</p>	<p>€ 360,00</p> <p>€ 410,00</p>
	<p>CT INVERTER NEW</p> <ul style="list-style-type: none"> - Quadro di comando per il controllo e l'azionamento di automazioni industriali a un motore monofase 230Vac 50Hz <u>senza condensatore di avviamento.</u> Con box semplice (BOX) o box con pulsanti apre, stop e chiude (BOX_B). <u>Ricevitore B.RO22W LED 2ch opzionale.</u> - Control board for the operating and controlling of industrial automations equipped with one single phase motor 230Vac 50Hz <u>without start capacitor.</u> With simple box (BOX) or box with open, stop and close buttons (BOX_B). <u>Optional B.RO22W LED 2ch receiver.</u> - Centrale de commande pour le contrôle et l'accionnement, d'automations industrielles à un moteur monophasé 230Vac 50Hz <u>sans condensateur.</u> Avec boîtier simple (BOX) ou boîtier avec boutons ouvre, stop et ferme (BOX_B). <u>Récepteur B.RO22W LED 2ch optionnel.</u> - Cuadro de mando para el control y el accionamiento de automatismos industriales de un motor monofasico 230Vac 50Hz <u>sin condensador de arranque.</u> Con caja simple (BOX) o caja con tecla abre, stop y cierra (BOX_B). <u>Receptor B.RO22W LED 2ch opcional.</u> 	<p>BOX 12006565</p> <p>BOX_B 12006569</p>	<p>€ 360,00</p> <p>€ 410,00</p>
	<p>B.RO22W LED 2ch</p> <ul style="list-style-type: none"> - Ricevitore rolling code 2 canali con connettore molex a 10 vie (ad innesto). Relè con selezione funzionamento impulsivo, passo-passo o temporizzato. - 2 channels rolling code receiver with 10 pins molex connector. Relay with selection of impulse, step by step or timer controlled function. - Récepteur rolling code 2 canaux avec connecteur à 10 voies (embrochable). Relais avec selection fonctionnement impulsif, pas à pas et temporisé. - Receptor rolling code con conector molex de 10 vías (enchufe). Relé con selección funcionamiento con impulsos, paso-paso o temporizado. 	<p>12006471</p>	<p>€ 45,00</p>



CENTRALINE PER 2 MOTORI 24V / CONTROL UNITS FOR 2 GEARMOTORS 24V CENTRALES DE COMMANDE POUR 2 MOTEURS 24V / CENTRALES DE MANDO PARA 2 MOTORES 24V CATALOGO / CATALOGUE / CATALOGUE / CATÁLOGO PAG. 44

	<p>BIOS2 24V</p> <ul style="list-style-type: none"> - Centralina per cancelli a 1 o 2 battenti 24Vdc. Selezione funzioni tramite display. - Control unit for 1 or 2 wings gate 24Vdc. Function selection by display. - Centrale de commande pour portails avec 1 ou 2 vantaux 24Vdc. Sélection fonctionne par display. - Central para cancelas de 1 o 2 hojas 24Vdc. Selección de funciones mediante display. 	<p>12006623</p>	<p>€ 245,00</p>
---	--	-----------------	-----------------

ACCESSORI / ACCESSORIES / ACCESSOIRES / ACCESORIOS

	<p>BLUETOOTH</p> <ul style="list-style-type: none"> - Modulo Bluetooth per centraline BIOS1 e BIOS2. - Bluetooth module for BIOS1 and BIOS2 control units. - Module Bluetooth pour centrales BIOS1 et BIOS2. - Módulo Bluetooth para centrales BIOS1 y BIOS2. 	<p>12006730</p>	<p>€ 95,00</p>
	<p>R1</p> <ul style="list-style-type: none"> - Scheda espansione funzioni per la centralina di comando 230 Vac. Contatti puliti per la gestione elettroserratura. - Card providing extended functions for the control unit 230 Vac. Dry contacts to control electrical lock. - Carte d'expansion des fonctions pour la centrale 230 Vac. Contacts secs pour la gestion de la serrure électrique. - Tarjeta para varios usos para la central de mando 230 Vac. Contactos sin voltaje para la gestión de cerradura eléctrica. 	<p>12000760</p>	<p>€ 13,00</p>

	<p>R2</p> <ul style="list-style-type: none"> - Scheda espansione funzioni per la centralina di comando BIOS 2 ECO o BIOS2 24V. Uscita elettroserratura e luce di cortesia. - Card providing extended functions for the BIOS 2 ECO or BIOS2 24V control unit. Dry contacts to control electrical lock and courtesy light. - Carte d'expansion des fonctions pour BIOS2 ECO et BIOS2 24V. Contacts secs pour la gestion de la serrure électrique et de la lumière de courtoisie. - Tarjeta ampliación funciones para la central de mando BIOS2 ECO y BIOS2 24V. Salida cerradura eléctrica y luz de cortesia. 	12001703	€ 15,00
	<p>RPEC1</p> <ul style="list-style-type: none"> - Regolatore di coppia a triac con uscita 230 Vac. Collegabile alla centralina tramite un comodo e pratico innesto guidato. - Torque adjuster with triac, with 230 Vac output. Connectable to the control unit by a comfortable and practical coupling. - Régulateur de couple à triac avec sortie 230 Vac. Embrochable à la centrale grâce à un confortable et pratique connecteur guidé. - Regulador de par con triac con salida 230 Vac. Se conecta a la central de mando a través de un cómodo y práctico conector a acoplamiento guiado. 	12000445	€ 13,00
	<p>24CBA</p> <ul style="list-style-type: none"> - Scheda carica batterie 24V ad innesto con controllo elettronico della carica. - 24V battery charger card with guided coupling guide and electronic control of charge level. - Carte chargeur de batterie 24V embrochable avec contrôle électronique de la charge. - Tarjeta enchufable para cargador de baterías 24V con control electrónico de la carga. 	12000780	€ 16,00
	<p>BATTERIA / BATTERY / BATTERIE / BATERÍA</p> <ul style="list-style-type: none"> - Batteria ricaricabile 12V, 1.3Ah. Dim. (mm) W x D x H = 98 X 45 X 50. - Rechargeable battery 12V, 1.3Ah. Dim. (mm) W x D x H = 98 X 45 X 50. - Batteries rechargeable 12V, 1.3Ah. Dim. (mm) W x D x H = 98 X 45 X 50. - Batería recargable 12V, 1.3Ah. Dim. (mm) W x D x H = 98 X 45 X 50. 	61400053	€ 28,00
	<p>BATTERIA / BATTERY / BATTERIE / BATERÍA</p> <ul style="list-style-type: none"> - Batteria ricaricabile 12V, 7.2Ah. Dim. (mm) W x D x H = 150 X 65 X 95. - Rechargeable battery 12V, 7.2Ah. Dim. (mm) W x D x H = 150 X 65 X 95. - Batteries rechargeable 12V, 7.2Ah. Dim. (mm) W x D x H = 150 X 65 X 95. - Batería recargable 12V, 7.2Ah. Dim. (mm) W x D x H = 150 X 65 X 95. 	61400056	€ 62,00
	<p>WINTER</p> <ul style="list-style-type: none"> - Scheda riscaldatore controllata in temperatura grazie ad una sonda di temperatura per motori 230 Vac. Regolazione tensione di riscaldamento attraverso comodi ponticelli. - Heater card for 230 Vac motors controlled through a thermostatic probe. Setting of heater voltage by comfortable jumper connections. - Carte de préchauffement pour moteurs 230 Vac contrôlé en température grâce à une sonde. Régulation tension de chauffage grâce à des confortables petits ponts. - Tarjeta calentadora. Control de temperatura por medio de una sonda detectora de temperatura para motores 230 Vac. Ajuste tensión de calefacción a través de cómodos puentecillos. 	12000770	€ 90,00
	<p>IB1.M</p> <ul style="list-style-type: none"> - Modulo radio ibrido banda larga. - Hybrid broad band radio module. - Module radio hybride à bande large. - Módulo radio híbrido banda ancha. 	12005691	€ 9,00
	<p>IB4 TDA 1</p> <ul style="list-style-type: none"> - Modulo radio ibrido banda stretta. - Hybrid narrow band radio module. - Module radio hybride à bande étroite. - Módulo radio híbrido banda estrecha. 	12005746	€ 15,00



	V9083 - Serratura elettrica, profilo cilindrico con contro bocchetta laterale, 12Vac 15VA. - Electrical lock, cylindrical profile, lateral plate, 12Vac 15VA. - Serrure électrique, profilé cylindrique avec contre embouchure latérale, 12Vac 15VA. - Cerradura eléctrica, perfil cilíndrico con contra boquilla lateral, 12Vac 15VA.	64100185	€ 185,00
	V06 - Serratura elettrica, contro bocchetta verticale, 12Vac 15VA. <u>Necessita di mezzocilindro (64100183).</u> - Electrical lock, vertical plate, 12Vac 15VA. <u>Half-cylinder needed (64100183).</u> - Serrure électrique, contre embouchure vertical, 12Vac 15VA. <u>Necessite de demi-cylindre (64100183).</u> - Cerradura eléctrica, contra boquilla vertical, 12Vac 15VA. <u>Necesita de medio cilindro (64100183).</u>	64100182 64100183	€ 139,00 € 29,00
	KIT BATTERIE / BATTERIES KIT / KIT BATTERIES / KIT BATERIAS - 2 batterie ricaricabili 12V, 1.3Ah. Cavo 1 mt. - 2 rechargeable batteries 12V, 1.3Ah. 1mt cable. - 2 batteries rechargeable 12V, 1.3Ah. Câble 1mt. - 2 baterias recargable 12V, 1.3Ah. Cable 1 mt.	12000757	€ 67,00



ROLLING CODE: TRASMETTITORI / TRANSMITTERS / TRANSMETTEURS / MANDOS

		Confezione (pz) Packing (pcs) Paquet (pcs) Paquete (pz)	Codice Code Code Código	Prezzo Price Prix Precios
	FOR4 - Alimentazione 12V con batteria tipo A27 di lunga durata. I trasmettitori FOR4 sono eleganti, robusti e di elevate prestazioni. - Power supply 12V, long – lasting battery A27. FOR4 transmitter are elegant, strong and high performing. - Alimentation 12V avec batterie type A27 de longue durée. Les transmetteurs FOR4 sont élégants, robustes et de performances élevées. - Alimentación 12V con batería tipo A27 de larga duración. Los mandos FOR4 son elegantes, robustos y de avanzadas prestaciones.	35	12006320	€ 26,00
	TECH3 PLUS - Alimentazione 3V con batteria al litio tipo CR2032 di lunga durata. I trasmettitori TECH3 PLUS sono eleganti, robusti, ultra sottili e di elevate prestazioni. - Power supply 3V, long – lasting CR2032 lithium battery. TECH3 PLUS transmitter are elegant, strong, ultra thin and high performing. - Alimentation 3V avec batterie au lithium type CR2032 de longue durée. Les transmetteurs TECH3 PLUS sont élégants, robustes, ultras plats et de performances élevées. - Alimentación 3V con batería de litio tipo CR2032 de larga duración. Los mandos TECH3 PLUS son elegantes, robustos, miniaturizados y de avanzadas prestaciones.	20	12006310	€ 25,00
	B.RO OVER - Alimentazione 3V con batteria al litio tipo CR2032 di lunga durata. I trasmettitori B.RO OVER sono eleganti, raffinati, ultra sottili e di grande tecnologia. - Power supply 3V, long – lasting CR2032 lithium battery. B.RO OVER are refined, ultra thin and highly technological transmitter. - Alimentation 3V avec batterie au lithium type CR2032 de longue durée. Les transmetteurs B.RO OVER sont élégants, raffinés, ultras plats et de haute technologie. - Alimentación 3V con batería de litio tipo CR2032 de larga duración. Los mandos B.RO OVER son elegantes, refinados, miniaturizado y de avanzada tecnología.	20	12005380	€ 25,00
	B.RO4WN - Alimentazione 12V con batteria tipo 23A di lunga durata. I trasmettitori B.RO BEST sono eleganti, robusti, e di elevate prestazioni. Versione 10mW, B.RO POWER2 e B.RO POWER4 per una maggiore portata. - Power supply 12V, long – lasting battery 23A. B.RO BEST is an elegant and high performances transmitter. Versions 10Mw, B.RO POWER2 and B.RO POWER4 for a superior range. - Alimentation 12V avec batterie type 23A de longue durée. Les transmetteurs B.RO BEST sont élégants, robustes, et de performances élevées. Version 10mW, B.RO POWER2 et B.RO POWER4 pour les plus grandes distances. - Alimentación 12V con batería tipo 23A de larga duración. Los mandos a distancia B.RO BEST son elegantes, resistentes y de óptimas prestaciones. Versión 10mW, B.RO POWER2 y B.RO POWER4 para un mayor alcance.	20	12005368	€ 26,00
	B.RO2WN - Alimentazione 12V con batteria tipo 23A di lunga durata. I trasmettitori B.RO BEST sono eleganti, robusti, e di elevate prestazioni. Versione 10mW, B.RO POWER2 e B.RO POWER4 per una maggiore portata. - Power supply 12V, long – lasting battery 23A. B.RO BEST is an elegant and high performances transmitter. Versions 10Mw, B.RO POWER2 and B.RO POWER4 for a superior range. - Alimentation 12V avec batterie type 23A de longue durée. Les transmetteurs B.RO BEST sont élégants, robustes, et de performances élevées. Version 10mW, B.RO POWER2 et B.RO POWER4 pour les plus grandes distances. - Alimentación 12V con batería tipo 23A de larga duración. Los mandos a distancia B.RO BEST son elegantes, resistentes y de óptimas prestaciones. Versión 10mW, B.RO POWER2 y B.RO POWER4 para un mayor alcance.	20	12005109	€ 23,00

		Confezione Packing Paquet Paquete	Codice Code Code Código	Prezzo Price Prix Precios
	B.RO POWER4 - Alimentazione 12V con batteria tipo 23A di lunga durata. I trasmettitori B.RO BEST sono eleganti, robusti, e di elevate prestazioni. Versione 10mW, B.RO POWER2 e B.RO POWER4 per una maggiore portata. Solo per mercati extra UE - Power supply 12V, long – lasting battery 23A. B.RO BEST is an elegant and high performances transmitter. Versions 10Mw, B.RO POWER2 and B.RO POWER4 for a superior range. Only for Extra UE markets - Alimentation 12V avec batterie type 23A de longue durée. Les transmetteurs B.RO BEST sont élégants, robustes, et de performances élevées. Version 10mW, B.RO POWER2 et B.RO POWER4 pour les plus grandes distances. Uniquement pour les marchés non européens - Alimentación 12V con batería tipo 23A de larga duración. Los mandos a distancia B.RO BEST son elegantes, resistentes y de óptimas prestaciones. Versión 10mW, B.RO POWER2 y B.RO POWER4 para un mayor alcance. Sólo para los mercados fuera de la UE	20	12005375	€ 50,00
	B.RO T12W - Alimentazione 12V con batteria tipo 23A di lunga durata. I trasmettitori B.RO BEST sono eleganti, robusti, e di elevate prestazioni. Versione 10mW, B.RO POWER2 e B.RO POWER4 per una maggiore portata. - Power supply 12V, long – lasting battery 23A. B.RO BEST is an elegant and high performances transmitter. Versions 10Mw, B.RO POWER2 and B.RO POWER4 for a superior range. - Alimentation 12V avec batterie type 23A de longue durée. Les transmetteurs B.RO BEST sont élégants, robustes, et de performances élevées. Version 10mW, B.RO POWER2 et B.RO POWER4 pour les plus grandes distances. - Alimentación 12V con batería tipo 23A de larga duración. Los mandos a distancia B.RO BEST son elegantes, resistentes y de óptimas prestaciones. Versión 10mW, B.RO POWER2 y B.RO POWER4 para un mayor alcance.	1	12005154	€ 52,00
	B.RO STAR - Alimentazione 3V con batteria al litio tipo CR2032 di lunga durata. I trasmettitori B.RO STAR sono i più piccoli sul mercato, è un elegante portachiavi, leggero, tecnologico, di grande prestigio. - Power supply 3V, long – lasting CR2032 lithium battery. B.RO STAR is the smallest transmitter currently available on the market; it is an elegant, light, technological and very precious key ring. - Alimentation 3V avec batterie au lithium type CR2032 de longue durée. Les transmetteurs B.RO STAR sont les plus petits sur le marché, c'est un porte-clefs élégant, léger, technologique, de grand prestige. - Alimentación 3V con batería de litio tipo CR2032 de larga duración. Los mandos B.RO STAR son los más pequeños del mercado, es un elegante portallaves, ligero, tecnológico y de gran prestigio.	2	12005106	€ 25,00
	PORT - Porta telecomando per trasmettitori B.RO2WN / B.RO4WN - Remote control holder for B.RO BEST transmitters B.RO2WN / B.RO4WN - Porte radiocommande pour les transmetteurs B.RO2WN / B.RO4WN - Portamando para mandos B.RO2WN / B.RO4WN	-	12005378	€ 2,00
	RK3 - Tastiera radio Rolling Code a 10 canali - 99 Utenti. Box in ABS con grado di protezione IP65. Tasti in policarbonato retroilluminati. Alimentazione a batteria 9V e/o con alimentatore 12 / 24 Vac / Vdc. - Radio Keyboard Rolling Code 10 channels - 99 Users. Box in ABS with protection rating IP65. Polycarbonate backlit function keys. 9 V battery power supply and/or 12 / 24 Vac / Vdc power generator. - Clavier radio Rolling Code à 10 canaux - 99 Utilisateurs. Box en ABS avec degré de protection IP65. Touches en polycarbonates rétro illuminés. Alimentation à batterie 9V et/ou avec alimentateur 12/24 Vac/dc. - Teclado Rolling Code de 10 canales - 99 usuarios. Caja de ABS con nivel de protección IP65. Teclas de policarbonato retroiluminado. Alimentación con batería de 9V y/o con alimentación 12/24 Vac/dc.	1	12005307	€ 135,00

ROLLING CODE: RICEVITORI / RECEIVERS / RÉCEPTEURS / RECEPTORES

	B.RO MINI 1CH - Micro ricevitore autonomo rolling code a 1 canale. Relè con selezione funzionamento immediato o temporizzato. Pre-cablato 30 cm. Con modulo radio a banda larga IB1.M. - Micro-Rolling code stand alone receiver with 1 channel. Relay with selection of immediate or timer controlled function. Pre-wired 30 cm. With broad band module radio IB1.M. - Micro récepteur rolling code autonome 1 canaux. Relais avec selection fonctionnement immediat et temporisé. Pré-câblés 30 cm. Avec module radio à bande large IB1.M - Micro receptor autónomo rolling code 1 canal. Relé con selección funcionamiento con immediato o temporizado. Precableado 30 cm. Con módulo radio banda ancha IB1.M.	Imballo singolo / Single package / emballage unique embalaje individual 12006482 Imballaggio industriale / Industrial package / emballage industrie / embalaje industrial 12006481	€ 32,00 € 29,00
	B.RO22W LED 2ch - Ricevitore rolling code 2 canali con connettore molex a 10 vie (ad innesto). Relè con selezione funzionamento impulsivo, passo-passo o temporizzato. - 2 channels rolling code receiver with 10 pins molex connector. Relay with selection of impulse, step by step or timer controlled function. - Récepteur rolling code 2 canaux avec connecteur à 10 voies (embrochable). Relais avec selection fonctionnement impulsif, pas à pas et temporisé. - Receptor rolling code con conector molex de 10 vías (enchufe). Relé con selección funcionamiento con impulsos, paso-paso o temporizado.	12006471	€ 45,00



	<p>B.RO22BWB LED 2ch</p> <ul style="list-style-type: none"> - Ricevitore rolling code 2 canali con morsettiera a 8 vie in box. Relè con selezione funzionamento impulsivo, passo-passo o temporizzato. - 2 channels rolling code receiver with 8 pins terminal boards. Relay with selection of impulse, step by step or timer controlled function. - Récepteur rolling code 2 canaux avec bornier à 8 voies en box. Relais avec selection fonctionnement impulsif, pas à pas et temporisé. - Receptor rolling code con tablero de bornes de 8 vías en caja. Relé con selección funcionamiento con impulsos, paso-paso o temporizado. 	12006472	€ 49,00
	<p>RX220/2/16M</p> <ul style="list-style-type: none"> - Ricevitore rolling code 2 canali. Relè 16A 230 Vac con selezione funzionamento impulsivo, passo-passo o temporizzato. Interfaccia base (BA. RX220/2/16M) compatibile con B.RO 22 LED con connettore a MOLEX. Alimentazione 230 Vac. - 2 channels rolling code receiver. Relay 16A 230 Vac with selection of impulse, step by step or timer controlled function. Base interface (BA. RX220/2/16M) compatible with B.RO 22 LED with MOLEX connector. Power supply 230 Vac. - Récepteur rolling code 2 canaux. Relais 16A 230 Vac avec selection fonctionnement impulsif, pas à pas et temporisé. Interface base (BA. RX220/2/16M) compatible avec B.RO 22 LED avec connecteur MOLEX. Alimentation 230 Vac. - Receptor rolling code 2 canales. Relé 16A 230 Vac con selección funcionamiento con impulsos, paso-paso o temporizado. Interfaz base (BA. RX220/2/16M) compatible con B.RO 22 LED con conector a MOLEX. Alimentación de 230 Vac. 	12005437	€ 93,00
	<p>B.RO X40 DISPLAY</p> <ul style="list-style-type: none"> - Ricevitore rolling code 4 canali. Relè 16A 230 Vac con selezione funzionamento impulsivo, passo-passo, temporizzato o ritardato. <u>Ricevitore con gestione di un trasmettitore tramite display.</u> - 4 channels rolling code receiver. Relay 16A 230 Vac with selection of impulse, step by step, timer controlled or delayed function. <u>Receiver with managing of a single transmitter through the display.</u> - Récepteur rolling code 4 canaux. Relais 16A 230 Vac avec selection fonctionnement impulsif, étape par étape, temporisé ou retardé. <u>Récepteur avec gestion d'un émetteur à travers le display.</u> - Receptor rolling code 4 canales. Relé 16A 230 Vac con selección función impulso, paso-paso, temporizado o retardado. <u>Receptor con gestión de un mando a través de display.</u> 	12005756	€ 80,00

FIX CODE: TRASMETTITORI & RICEVITORI / TRANSMITTERS & RECEIVERS / TRANSMETTEURS & RÉCEPTEURS / MANDOS & RECEPTORES



CATALOGO / CATALOGUE / CATALOGUE / CATÁLOGO PAG. 49

	<p>AEMX2</p> <ul style="list-style-type: none"> - Trasmettitori a 2 canali di tradizionale funzionalità e semplicità con 1024 combinazioni a dip-switch e codifica digitale. Dip-switch di selezione canali. Alimentazione 12V con batteria tipo 23A. - 2 channels transmitters, with simple and traditional functions. 1024 dip switch combinations and digital coding. Dip switch to select the channels. Power supply 12V with battery 23A. - Transmetteurs à 2 canaux de fonctionnalité et simplicité traditionnelle avec 1024 combinaisons à dip-switch et code digital. Dip-switch de sélection canaux. Alimentation 12V avec batterie type 23A. - Mando a distancia de 2 canales de tradicional funcionalidad y sencillez, con 1024 combinaciones de dip-switch y codificación digital. Dip-switch de selección de canales. Alimentación 12V con batería tipo 23A. 	12005010	€ 25,00
	<p>AEMX4</p> <ul style="list-style-type: none"> - Trasmettitori a 4 canali di tradizionale funzionalità e semplicità con 1024 combinazioni a dip-switch e codifica digitale. Dip-switch di selezione canali. Alimentazione 12V con batteria tipo 23A. - 4 channels transmitters, with simple and traditional functions. 1024 dip switch combinations and digital coding. Dip switch to select the channels. Power supply 12V with battery 23A. - Transmetteurs à 4 canaux de fonctionnalité et simplicité traditionnelle avec 1024 combinaisons à dip-switch et code digital. Dip-switch de sélection canaux. Alimentation 12V avec batterie type 23A. - Mando a distancia de 4 canales de tradicional funcionalidad y sencillez, con 1024 combinaciones de dip-switch y codificación digital. Dip-switch de selección de canales. Alimentación 12V con batería tipo 23A. 	12005020	€ 27,00
	<p>MX2</p> <ul style="list-style-type: none"> - Trasmettitori a 2 canali di tradizionale funzionalità e semplicità con 1024 combinazioni a dip-switch e codifica digitale. Dip-switch di selezione canali. Alimentazione 12V con batteria tipo 23A. - 2 channels transmitters, with simple and traditional functions. 1024 dip switch combinations and digital coding. Dip switch to select the channels. Power supply 12V with battery 23A. - Transmetteurs à 2 canaux de fonctionnalité et simplicité traditionnelle avec 1024 combinaisons à dip-switch et code digital. Dip-switch de sélection canaux. Alimentation 12V avec batterie type 23A. - Mando a distancia de 2 canales de tradicional funcionalidad y sencillez, con 1024 combinaciones de dip-switch y codificación digital. Dip-switch de selección de canales. Alimentación 12V con batería tipo 23A. 	12005018	€ 25,00
	<p>MX4</p> <ul style="list-style-type: none"> - Trasmettitori a 4 canali di tradizionale funzionalità e semplicità con 1024 combinazioni a dip-switch e codifica digitale. Dip-switch di selezione canali. Alimentazione 12V con batteria tipo 23A. - 4 channels transmitters, with simple and traditional functions. 1024 dip switch combinations and digital coding. Dip switch to select the channels. Power supply 12V with battery 23A. - Transmetteurs à 4 canaux de fonctionnalité et simplicité traditionnelle avec 1024 combinaisons à dip-switch et code digital. Dip-switch de sélection canaux. Alimentation 12V avec batterie type 23A. - Mando a distancia de 4 canales de tradicional funcionalidad y sencillez, con 1024 combinaciones de dip-switch y codificación digital. Dip-switch de selección de canales. Alimentación 12V con batería tipo 23A. 	12005026	€ 27,00
	<p>ASR2B 433/AP LED</p> <ul style="list-style-type: none"> - Ricevitore a scheda in box 2 canali con morsettiera a 8 poli, autoapprendimento. - 2 channels receiver with box, with 8 pin terminal strip, autolearning system. - Récepteur en box 2 canaux avec bornier à 8 voies, auto apprentissage - Receptor en caja, 2 canales con tablero de bornes de 8 vías, autoaprendizaje. 	12005494	€ 60,00



KIT AUTOSET MOVEO 24V 700Kg

	<p>KIT AUTOSET MOVEO 24V 700kg</p> <ul style="list-style-type: none"> - Automazione completa 24Vdc per cancelli scorrevoli. - Complete automation 24Vdc for sliding gates. - Automation complète 24Vdc pour portails coulissants. - Automatización completa 24Vdc para puertas correderas. 	<p>AUTOSET MOVEO 24V</p> <ul style="list-style-type: none"> • n°1 MOVEO 24V ; • n°2 B.RO2WN; • n°1 AL300÷433; • n°1 B.RO LIGHT FIX 24Vac; • n°1 SUP L; • n°1 FTALL7 		<p>12008491</p>	<p>€ 570,00</p>
--	--	---	---	-----------------	-----------------

KIT AUTOSET MOVEO 230V 600Kg

	<p>KIT AUTOSET MOVEO 600</p> <ul style="list-style-type: none"> - Automazione completa 230Vac per cancelli scorrevoli. - Complete automation 230Vac for sliding gates. - Automation complète 230Vac pour portails coulissants. - Automatización completa 230Vac para puertas correderas. 	<p>AUTOSET MOVEO 600</p> <ul style="list-style-type: none"> • n°1 MOVEO 600; • n°2 B.RO2WN; • n°1 AL300÷433; • n°1 B.RO LIGHT FIX 230Vac; • n°1 SUP L; • n°1 FTALL7 		<p>12008485</p>	<p>€ 520,00</p>
--	--	---	---	-----------------	-----------------

KIT AUTOSET MOVEO 230V 800Kg*

	<p>KIT AUTOSET MOVEO 800</p> <ul style="list-style-type: none"> - Automazione completa 230Vac per cancelli scorrevoli. - Complete automation 230Vac for sliding gates. - Automation complète 230Vac pour portails coulissants. - Automatización completa 230Vac para puertas correderas. 	<p>AUTOSET MOVEO 800</p> <ul style="list-style-type: none"> • n°1 MOVEO 800; • n°2 B.RO2WN; • n°1 AL300÷433; • n°1 B.RO LIGHT FIX 230Vac; • n°1 SUP L; • n°1 FTALL7 		<p>12008487*</p>	<p>€ 600,00</p>
---	--	---	--	------------------	-----------------

* Disponibile da giugno 2019 / Available from June 2019 / Disponible depuis juin 2019 / Disponible desde junio 2019

KIT AUTOSET KALOS XL 24V 1000Kg

	<p>KIT AUTOSET KALOS XL 24V 1000kg</p> <ul style="list-style-type: none"> - Automazione completa 24Vdc per cancelli scorrevoli. - Complete automation 24Vdc for sliding gates. - Automation complète 24Vdc pour portails coulissants. - Automatización completa 24Vdc para puertas correderas. 	<p>AUTOSET KALOS XL 24V</p> <ul style="list-style-type: none"> • n°1 KALOS XL 24V ; • n°2 B.RO2WN; • n°1 AL300÷433; • n°1 B.RO LIGHT FIX 24Vac; • n°1 SUP L; • n°1 FTALL7 		<p>12008447</p>	<p>€ 720,00</p>
--	--	---	--	-----------------	-----------------

KIT AUTOSET KALOS XL 800Kg

	<p>KIT AUTOSET KALOS XL 800</p> <ul style="list-style-type: none"> - Automazione completa 230Vac per cancelli scorrevoli. - Complete automation 230Vac for sliding gates. - Automation complète 230Vac pour portails coulissants. - Automatización completa 230Vac para puertas correderas. 	<p>AUTOSET KALOS XL 800</p> <ul style="list-style-type: none"> • n°1 KALOS XL 800; • n°2 B.RO2WN; • n°1 AL300÷433; • n°1 B.RO LIGHT FIX 230Vac; • n°1 SUP L; • n°1 FTALL7 		<p>12008446</p>	<p>€ 620,00</p>
--	---	---	--	-----------------	-----------------

* Disponibile fino a giugno 2019 / Available until June 2019 / Disponible jusqu'à juin 2019 / Disponible hasta junio 2019

KIT AUTOSET KALOS 1200Kg

	<p>KIT AUTOSET KALOS XL 1200</p> <ul style="list-style-type: none"> - Automazione completa 230Vac per cancelli scorrevoli. - Complete automation 230Vac for sliding gates. - Automation complète 230Vac pour portails coulissants. - Automatización completa 230Vac para puertas correderas. 	<p>AUTOSET KALOS XL 120</p> <ul style="list-style-type: none"> • n°1 KALOS XL 1200; • n°2 B.RO2WN; • n°1 AL300÷433; • n°1 B.RO LIGHT FIX 230Vac; • n°1 SUP L; • n°1 FTALL7 		<p>12008445</p>	<p>€ 660,00</p>
--	--	--	--	-----------------	-----------------

KIT AUTOSET KINEO 400

	<p>KIT AUTOSET KINEO 400</p> <ul style="list-style-type: none"> - Automazione completa 230Vac per cancelli a battente. - Complete automation 230Vac for wing gates. - Automation complète 230Vac pour portails battants. - Automatización completa 230Vac para puertas a hojas. 	<p>AUTOSET KINEO 400:</p> <ul style="list-style-type: none"> • n°2 KINEO 400; • n°1 BIOS2; • n°2 B.RO2WN; • n°1 AL300÷433; • n°1 B.RO LIGHT FIX 230Vac; • n°1 SUP L; • n°1 FTALL7. 	<p>12008271</p>	<p>€ 755,00</p>
--	---	---	-----------------	-----------------

KIT AUTOSET KINEO 400 24V

	<p>KIT AUTOSET KINEO 400 24V</p> <ul style="list-style-type: none"> - Automazione completa 24Vdc per cancelli a battente. - Complete automation 24Vdc for wing gates. - Automation complète 24Vdc pour portails battants. - Automatización completa 24Vdc para puertas a hojas. 	<p>AUTOSET KINEO 400:</p> <ul style="list-style-type: none"> • n°2 KINEO 400 24V; • n°1 BIOS2 24V; • n°2 B.RO2WN; • n°1 AL300÷433; • n°1 B.RO LIGHT FIX 24Vac; • n°1 SUP L; • n°1 FTALL7. 	<p>12008292</p>	<p>€ 806,00</p>
--	---	--	-----------------	-----------------

KIT AUTOSET XTILUS

	<p>KIT AUTOSET XTILUS</p> <ul style="list-style-type: none"> - Automazione completa 230Vac per cancelli a battente. - Complete automation 230Vac for wing gates. - Automation complète 230Vac pour portails battants. - Automatización completa 230Vac para puertas a hojas. 	<p>AUTOSET XTILUS:</p> <ul style="list-style-type: none"> • n°2 XTILUS; • n°1 BIOS2; • n°2 B.RO2WN; • n°1 AL300÷433; • n°1 B.RO LIGHT FIX 230Vac; • n°1 SUP L; • n°1 FTALL7. 	<p>12008277</p>	<p>€ 955,00</p>
---	--	---	-----------------	-----------------

KIT AUTOSET XTILUS 24V

	<p>KIT AUTOSET XTILUS 24V</p> <ul style="list-style-type: none"> - Automazione completa 24Vdc per cancelli a battente. - Complete automation 24Vdc for wing gates. - Automation complète 24Vdc pour portails battants. - Automatización completa 24Vdc para puertas a hojas. 	<p>AUTOSET XTILUS 24V:</p> <ul style="list-style-type: none"> • n°2 XTILUS 24V; • n°1 BIOS2 24V; • n°2 B.RO2WN; • n°1 AL300÷433; • n°1 B.RO LIGHT FIX 24Vac; • n°1 SUP L; • n°1 FTALL7. 	<p>12008294</p>	<p>€ 1.025,00</p>
--	--	--	-----------------	-------------------

KIT AUTOSET PLUS L ADVANCE

	<p>KIT AUTOSET PLUS L ADVANCE</p> <ul style="list-style-type: none"> - Automazione completa 230Vac per cancelli a battente. - Complete automation 230Vac for wing gates. - Automatisation complète 230Vac pour portails battants. - Automatización completa 230Vac para puertas a hojas. <p>AUTOSET PLUS L ADVANCE:</p> <ul style="list-style-type: none"> • n°2 PLUS L; • n°1 BIOS2; • n°2 B.RO2WN; • n°1 AL300=433; • n°1 B.RO LIGHT FIX 230Vac; • n°1 SUP L; • n°1 FTALL7. 	12008212	€ 1.175,00
--	--	----------	------------



KIT AUTOSET INT VS 24V



	<p>KIT AUTOSET INT VS</p> <ul style="list-style-type: none"> - Automazione completa 24Vdc per cancelli a battente. - Complete automation 24Vdc for wing gates. - Automatisation complète 24Vdc pour portails battants. - Automatización completa 24Vdc para puertas a hojas. <p>AUTOSET INT VS:</p> <ul style="list-style-type: none"> • n°2 INT VS; • n°2 CAC20; • n°1 BIOS2 24V • n°2 B.RO2WN; • n°1 AL300=433; • n°1 B.RO LIGHT FIX 24Vac; • n°1 SUP L; • n°1 FTALL7; • n°2 SBL-LEVS. 	12008266	€ 1.715,00
--	---	----------	------------

KIT AUTOSET INT R/XL



	<p>KIT AUTOSET INT R/XL</p> <ul style="list-style-type: none"> - Automazione completa 230Vac per cancelli a battente. - Complete automation 230Vac for wing gates. - Automatisation complète 230Vac pour portails battants. - Automatización completa 230Vac para puertas a hojas. <p>AUTOSET INT R/XL:</p> <ul style="list-style-type: none"> • n°2 INT R/XL; • n°2 CAC20; • n°1 BIOS2; • n°2 B.RO2WN; • n°1 AL300=433; • n°1 B.RO LIGHT FIX 230Vac; • n°1 SUP L; • n°1 FTALL7. • n°2 SBL-LEVS. 	12008252	€ 1.800,00
--	---	----------	------------

FOTOCELLULE / PHOTOCELLS / PHOTOCELLULES / FOTOCELULAS

	<p>FT00/7</p> <ul style="list-style-type: none"> - Fotocellula da esterno dal design raffinato e coordinato, materiale filtro-trasparente ai raggi infrarossi. Completa di accessori per un montaggio professionale. Massima immunità ai disturbi, lente di Fresnel e guida luce, portata selezionabile da 8m a 30m, sincronizzabile. - Outdoor Photocell with a refined design, in IR transparent filtering material. Complete with accessories for a professional assembling. Maximum immunity to disturbances, Fresnel lens and light guide, selectable range from 8m to 30m, synchronized. - Photocellule d'extérieur, design raffiné et assorti, en matériel filtre transparent aux rayons infrarouges. Complète des accessoires pour un assemblage professionnel. Immunité maximale aux perturbations, lentille Fresnel et guide de lumière, Portée sélectionnable de 8m à 30m, synchronisée. - Fotocélula para exteriores, elegante diseño, realizado en material filtro-trasparente a rayos infrarrojos. Provista de pequeños accesorios para un montaje profesional. Máxima inmunidad a perturbaciones, lente Fresnel y guía de luz, Alcance seleccionable de 8m a 30m, sincronizado. 	12005934	€ 34,00
	<p>FTALL7</p> <ul style="list-style-type: none"> - Fotocellula da esterno dal design raffinato e coordinato, materiale filtro-trasparente ai raggi infrarossi. Completa di accessori per un montaggio professionale. Massima immunità ai disturbi, lente di Fresnel, portata 25m, sincronizzabile. - Outdoor Photocell with a refined design, in IR transparent filtering material. Complete with accessories for a professional assembling. Maximum immunity to disturbances, Fresnel lens, range 25m, synchronized. - Photocellule d'extérieur, design raffiné et assorti, en matériel filtre transparent aux rayons infrarouges. Complète des accessoires pour un assemblage professionnel. Immunité maximale aux perturbations, lentille Fresnel, Portée 25m, synchronisée. - Fotocélula para exteriores, elegante diseño, realizado en material filtro-trasparente a rayos infrarrojos. Provista de pequeños accesorios para un montaje profesional. Máxima inmunidad a perturbaciones, lente Fresnel, Alcance 25m, sincronizado. 	12005933	€ 30,00
	<p>FTC 60N & FTC 110N</p> <ul style="list-style-type: none"> - Colonnine di supporto extrapiatte, in alluminio estruso, design, estetica e funzionalità. Pezzi singoli. - FTc 60N: H 60 mm per 1 fotocellula e supporto mobile. FTc 110N: H 110 mm per 2 fotocellule e supporto mobile. - Ultrathin extruded aluminium columns, functional with great design. Single parts. - FTc 60N: H 60 cm for 1 photocell and mobile support. FTc 100N: H 110 cm for 2 photocells and mobile support. - Colonnes de support extra plates, en aluminium extrudé, design, esthétique et fonctionnalité. Pièces individuelles. - FTc 60N: H 60 mm pour 1 photocellule et support mobile. FTc 110N: H 110 mm pour 2 photocellules et support mobile. - Columnas de soporte extraplanas en aluminio, diseño, estética y funcionalidad. Piezas individuales. - FTc 60N: H 60 mm para 1 fotocélula y soporte móvil. FTc 100N: H 110 mm para 2 fotocélulas y soporte móvil. 	<p>FTC 60N 12000880</p> <p>FTC 110N 12000890</p>	<p>€ 60,00</p> <p>€ 108,00</p>

	<p>AFT30</p> <ul style="list-style-type: none"> - Fotocellula da parete a canale singolo. - Outdoor single channel photocell. - Photocellule murale à canal unique - Fotocélula de pared con único canal 	61401020	€ 76,00
	<p>L40</p> <ul style="list-style-type: none"> - Contenitore a murare in ABS. - Box for built-in installation. - Box à murer en ABS - Contenedor de pared en ABS 	64100194	€ 2,80
	<p>FT-RIF</p> <ul style="list-style-type: none"> - Fotocellule a riflessione. - Reflection photocells. - Photocellules à réflexion. - Fotocélula a reflexión. 	12005960	€ 80,00

	<p>AFT25B</p> <ul style="list-style-type: none"> - Fotocellule a batterie. - Battery photocells. - Photocellules à batterie. - Fotocélula con batería. 	12005965	€ 70,00
	<ul style="list-style-type: none"> - Batterie 3,6V 2,7Ah non incluse. 2 necessarie. - Batteries 3,6V 2,7Ah not included. 2 required. - Batteries 3,6V 2,7Ah pas inclus. 2 nécessaires. - Baterías 3,6V 2,7Ah no incluido. 2 necesarias. 	61400004	€ 15,00

	<p>BLD: Box in alluminio da esterno con pulsante e leva di sblocco. BLD: Aluminium box for external installation with button and releasing lever. BLD: Box en aluminium d'extérieur avec bouton et levier de déblocage. BLD: Caja de aluminio para exteriores con botón y palanca de desbloqueo.</p> <p>CA-BLD: Cassetta per fissaggio esterno BLD. CA-BLD: Box for external installation of BLD. CA-BLD: boîte pour fixation externe BLD. CA-BLD: Caja por fijado externo BLD.</p>	<p>BLD 64100015</p> <p>CA-BLD 64100016</p>	<p>€ 70,00</p> <p>€ 12,00</p>
	<p>BLDR: Box in alluminio da esterno con pulsante e leva di sblocco. BLDR: Aluminium box for external installation with button and releasing lever. BLDR: Box en aluminium d'extérieur avec bouton et levier de déblocage. BLDR: Caja de aluminio para exteriores con botón y palanca de desbloqueo.</p> <p>BLDR/I: Box in alluminio da incasso con pulsante e leva di sblocco. BLDR/I: Aluminium box for built-in installation with button and releasing lever. BLDR/I: Box en aluminium à muré avec bouton et levier de déblocage. BLDR/I: Caja de aluminio para empotrar con botón y palanca de desbloqueo.</p>	<p>BLDR 64100248</p> <p>BLDR/I 64100252</p>	<p>€ 78,00</p> <p>€ 80,00</p>

ANTENNE / ANTENNAS / ANTENNES / ANTENNAS



CATALOGO / CATALOGUE / CATALOGUE / CATÁLOGO PAG. 55

	<p>A300/433</p> <ul style="list-style-type: none"> - Antenna accordata standard 300 ÷ 433 MHz con cavo 4,5 metri. - Standard tuned antenna 300 ÷ 433 MHz with 4,5 meters cable. - Antenne standard accordée 300 ÷ 433 MHz avec 4,5 mètres de câble. - Antena sintonizada standard 300 ÷ 433 MHz con cable 4,5 metros. 	63601052	€ 23,00
	<p>AL300÷433</p> <ul style="list-style-type: none"> - Inserto antenna 300 ÷ 433 MHz da abbinare al lampeggiante con cavo 3 metri. - Antenna insert 300 ÷ 433 MHz to be combined with a flashing light with 3 meters cable. - Antenne insert 300 ÷ 433 MHz à assortir au clignotant avec 3 mètres de câble. - Antena con suplemento 300 ÷ 433 MHz para combinar con luz intermitente con cable 3 metros. 	53601055	€ 23,00
	<p>AL300÷433 Ex</p> <ul style="list-style-type: none"> - Inserto antenna 300 ÷ 433 MHz da abbinare al lampeggiante con cavo 5 metri. - Antenna insert 300 ÷ 433 MHz to be combined with a flashing light with 5 meters cable. - Antenne insert 300 ÷ 433 MHz à assortir au clignotant avec 5 mètres de câble. - Antena con suplemento 300 ÷ 433 MHz para combinar con luz intermitente con cable 5 metros. 	53601058	€ 26,00
	<p>PRO433</p> <ul style="list-style-type: none"> - Antenna professionale accordata a 433 MHz ad alto rendimento con cavo 2 metri. - Professional tuned antenna 433 MHz with high performance with 2 meters cable. - Antenne professionnelle accordée à 433MHz au haut rendement avec 2 mètres de câble. - Antena profesional sintonizada de alto rendimiento 433MHz con cable 2metros. 	63601006	€ 50,00





LAMPEGGIANTI / FLASHING LIGHTS / CLIGNOTANTS / LUZ INTERMITENTE

CATALOGO / CATALOGUE / CATALOGUE / CATÁLOGO PAG. 55

	<p>B.RO LIGHT 230V 40W</p> <p>Lampeggiante a luce gialla con circuito di autolampeggio, 230Vac 40W. Yellow flashing light with flashing circuit or with fix light, 230Vac 40W. Clignotant à lumière jaune avec circuit d'auto clignotement, 230Vac 40W. Luz intermitente de luz amarilla con circuito de autodesstello, 230Vac 40W.</p>	12000551	€ 26,00
---	---	----------	---------

	B.RO LIGHT 24V 25W - Lampeggiante a luce gialla con circuito di autolampeggio, 24Vac 25W. - Yellow flashing light with flashing circuit or with fix light, 24Vac 25W. - Clignotant à lumière jaune avec circuit d'auto clignotement, 24Vac 25W. - Luz intermitente de luz amarilla con circuito de autodestello, 24Vac 25W.	12000566	€ 27,00
	B.RO LIGHT FIX 230V 40W - Lampeggiante a luce gialla con luce fissa, 230Vac 40W. - Yellow flashing light with fix light, 230Vac 40W. - Clignotant à lumière jaune avec lumière fixe, 230Vac 40W. - Luz intermitente de luz amarilla con luz fija, 230Vac 40W.	12000553	€ 16,00
	B.RO LIGHT FIX 24V 25W - Lampeggiante a luce gialla con luce fissa, 24Vac 25W. - Yellow flashing light with fix light, 24Vac 25W. - Clignotant à lumière jaune avec lumière fixe, 24Vac 25W. - Luz intermitente de luz amarilla con luz fija, 24Vac 25W.	12000541	€ 16,00
	SUP L - Supporto da parete. - Holder for wall. - Support mural. - Soporte de pared.	12000530	€ 4,20

LAMPEGGIANTI A LED / LED FLASHING LIGHTS / CLIGNOTANTS À LED / LUZ INTERMITENTE A LED
CATALOGO / CATALOGUE / CATALOGUE / CATÁLOGO PAG. 55



	B.RO LIGHT LED 230V Lampeggiante a luce gialla con circuito di autolampeggio, 230Vac. Yellow flashing light with flashing circuit or with fix light, 230Vac. Clignotant à lumière jaune avec circuit d'auto clignotement, 230Vac. Luz intermitente de luz amarilla con circuito de autodestello, 230Va.	12000592	€ 30,00
	B.RO LIGHT LED 24V - Lampeggiante a luce gialla con circuito di autolampeggio, 24Vac. - Yellow flashing light with flashing circuit or with fix light, 24Vac. - Clignotant à lumière jaune avec circuit d'auto clignotement, 24Vac. - Luz intermitente de luz amarilla con circuito de autodestello, 24Vac.	12000584	€ 34,00
	B.RO LIGHT LED FIX 230V - Lampeggiante a luce gialla con luce fissa, 230Vac. - Yellow flashing light with fix light, 230Vac. - Clignotant à lumière jaune avec lumière fixe, 230Vac. - Luz intermitente de luz amarilla con luz fija, 230Vac.	12000591	€ 24,00
	B.RO LIGHT LED FIX 24V - Lampeggiante a luce gialla con luce fissa, 24Vac. - Yellow flashing light with fix light, 24Vac. - Clignotant à lumière jaune avec lumière fixe, 24Vac. - Luz intermitente de luz amarilla con luz fija, 24Vac.	12000593	€ 23,00

	SUP L - Supporto da parete. - Holder for wall. - Support mural. - Soporte de pared.	12000530	€ 4,20
--	--	----------	--------

PRODOTTI A RICHIESTA / PRODUCTS ON DEMAND
PRODUITS SUR DEMANDE / PRODUCTOS ESPECIALES BAJO PEDIDO
CATALOGO / CATALOGUE / CATALOGUE / CATÁLOGO PAG. 56



	IND4000V/I - Motoriduttore trifase (230 Vac) per cancelli scorrevoli fino a 4000 Kg. Centralina CT INVERTER incorporata. <u>Contropiastra di fissaggio inclusa. Ricevitore B.R022W LED 2ch incluso.</u> -Three-phase gearmotor (230 Vac) for sliding gates up to a weight of 4000 Kg. CT INVERTER control unit on-board. <u>Backing plate included. B.R022W LED 2ch receiver included.</u> - Motoréducteur (230 Vac) pour portails coulissants jusqu'à 4000 Kg. Centrale CT INVERTER incorporée. <u>Contre plaque de fixation inclus. Récepteur B.R022W LED 2ch inclus.</u> - Motorreductor trifásico (230 Vac) para puertas correderas de hasta 4000 Kg. Central de mando CT INVERTER incorporada. <u>Placa de fijación incluida. Receptor B.R022W LED 2ch incluido.</u>	12007103	€ 2.170,00
	IND4000V/T - Motoriduttore trifase (400 Vac) per cancelli scorrevoli fino a 4000 Kg. Centralina CT3IND incorporata. <u>Contropiastra di fissaggio inclusa.</u> -Three-phase gearmotor (400 Vac) for sliding gates up to a weight of 4000 Kg. CT3IND control unit on-board. <u>Backing plate included.</u> - Motoréducteur (400 Vac) pour portails coulissants jusqu'à 4000 Kg. Centrale CT3IND incorporée. <u>Contre plaque de fixation inclus.</u> - Motorreductor trifásico (400 Vac) para puertas correderas de hasta 4000 Kg. Central de mando CT3IND incorporada. <u>Placa de fijación incluida.</u>	12007104	€ 2.130,00
	SO400-IT 230V COPPIA / COUPLE / COUPLE / PAREJA - Coppia di motoriduttori (destra / sinistra) 230Vac per cancelli a battente da fino a 3 metri 350Kg. <u>Staffe di fissaggio incluse.</u> - Gearmotors couple (right / left) 230Vac for wing gates up to 3 meters 350Kg. <u>Mounting brackets included.</u> - Couple de motoréducteurs (droite / gauche) 230 Vac pour portails battants jusqu'à 3 mètres 350Kg. <u>Supports de fixation inclus.</u> - Pareja de motorreductores (derecha / izquierda) 230 Vac para puertas a hojas de hasta 3 metros 350Kg. <u>Soporte de fijación incluido.</u>	12007444	€ 446,00
	SER 24 - Operatore per serrande avvolgibili bilanciate con molle. Completati di elettrofreno con cavo, guaina e pomello di sblocco. - Gearmotor for spring balanced roll-up shutters. Including electronic brake with cable, case and releasing knob. - Opérateur pour rideaux enroulables équilibré à ressorts. Complète de frein électrique avec câble, gaine et pommeau de déblocage. - Operador para persianas enrollables equilibradas con muelles. Con electrofreno completo con cable, revestimiento y pomo de desbloqueo.	64000138	€ 305,00
	SER BIG TWO - Operatore con doppio motore per serrande avvolgibili bilanciate con molle di grandi dimensioni. Completati di elettrofreno con cavo, guaina e pomello di sblocco. - Operator with double motor for roll-up shutters balanced with big springs. Including electronic brake with cable, case and releasing knob. - Opérateur avec double moteur pour rideaux enroulables équilibré à ressorts de grandes dimensions. Complète de frein électrique avec câble, gaine et pommeau de déblocage. - Operador con doble motor para persianas enrollables equilibradas con muelles de grandes dimensiones. Con electrofreno completo con cable, revestimiento y pomo de desbloqueo.	64000139	€ 620,00
	FR5 - Elettrofreno completo di cavo, guaina e pomello di sblocco per SER 24, BIG TWO. - Electronic brake including cable, case and releasing knob for SER 24, BIG TWO. - Frein électrique complet de câble, gaine et pommeau de déblocage SER 24, BIG TWO. - Elettrofreno completo con cable, revestimiento y pomo de desbloqueo, SER 24, BIG TWO.	64100200	€ 59,00
	- Coppia semigusci Ø 76/102 per SER BIG TWO. - Couple of half shells Ø 76/102 for SER BIG TWO. - Paire de demi-coques pour réduction du mât Ø 76/102 pour SER BIG TWO. - Par semicircular Ø 76/102 para SER BIG TWO.	64100201	€ 22,00

ACCESSORI / ACCESSORIES / ACCESSOIRES / ACCESORIOS

	<p>A1H-U Rilevatore di presenza veicoli, amplificatore per spire magnetiche a 1 relé. Vehicle presence detector amplifier for magnetic loops with 1 relay. Détecteur de présence véhicule, amplificateur pour spire magnétique à 1 relais. Detector de presencia de vehículos, amplificador para espiras magnéticas de 1 relé.</p>	<p>12000820</p>	<p>€ 178,00</p>
	<ul style="list-style-type: none"> - Spira da interrare cavo 2x1, lunghezza 20 m. - Underground magnetic loops, 2x1 cable length 20m. - Spire à enterrer câble 2x1, longueur 20 m. - Spira de enterrar, cable de 2x1, 20 m de longitud. <ul style="list-style-type: none"> - Spira da interrare cavo 3x2, lunghezza 20 m. - Underground magnetic loops, 3x2 cable length 20m. - Spire à enterrer câble 3x2, longueur 20 m. - Spira de enterrar, cable de 3x2, 20 m de longitud. 	<p>61402030</p>	<p>€ 45,00</p>
	<p>PLK - Selettore a chiave da esterno in alluminio presso fuso; 2 contatti micro. - External die-cast aluminium key selector; 2 micro-switch. - Sélecteur à clé d'extérieur en aluminium moulé sous pression; 2 contacts micro. - Selector de llave para exterior en fundición de aluminio; 2 microcontactos.</p>	<p>64100009</p>	<p>€ 33,00</p>

CONTROLLO ACCESSI / ACCESS CONTROL / CONTRÔLE D'ACCÈS / CONTROL DE ACCESO

CATALOGO / CATALOGUE / CATALOGUE / CATÁLOGO PAG. 40-41

	<p>EM1</p> <ul style="list-style-type: none"> - Lettore tag di prossimità autonomo, 200 utenti, 1 relè di uscita, 12/24Vdc, tamper magnetico. - Stand alone mini-tag proximity reader, 200 users, 1 output relay, 12/24Vdc, magnetic tamper. - Lecteur tag de proximité autonome, 200 utilisateurs, 1 relais de sortie, 12/24Vdc, tamper magnétique. - Lector tag de proximidad autónomo, 200 usuarios, 1 relé de salida, 12/24Vdc, tamper magnético. 	12008700	€ 165,00
	<p>AM1 PAD</p> <ul style="list-style-type: none"> - Tastiera controllo accessi autonoma, retroilluminata, 1000 utenti, 2 relè di uscita, 12/24Vdc, tamper ottico. - Stand alone access control keypad, backlighted, 1000 users, 2 output relays, 12/24Vdc, optical tamper. - Clavier contrôle accès autonome, 1000 utilisateurs, 2 relais de sortie, 12/24Vdc, tamper optique. - Teclado control entrada autónoma, retroiluminado, 1000 usuarios, 2 relé de salida, 12/24Vdc, tamper óptico. 	12008725	€ 164,00
	<p>M2E</p> <ul style="list-style-type: none"> - Centralina controllo accessi, 2000 utenti, ricevitore radio Allmatic 433.92 Mhz, 2 ingressi per lettore di prossimità, 2 relè di uscita, gestione a display degli utenti, 12/24 Vac/dc. - Control unit for access control, 2000 users, 433.92 Mhz Allmatic radio receiver, 2 inputs for proximity reader, 2 output relays, users managed via display, 12/24 Vac/dc. - Centrale contrôle accès, 2000 utilisateurs, récepteur radio Allmatic 433.92 Mhz, 2 entrées pour lecteur de proximité, 2 relais de sortie, gestion par afficheur des utilisateurs, rapide et facile insertion et effacement des utilisateurs 12/24 Vac/dc. - Central control entrada, 2000 usuarios, receptor radio Allmatic 433.92 Mhz, 2 entradas para lector de proximidad, 2 relé de salida, gestión a display de los usuarios, rápido y fácil inserción y anulación de los usuarios 12/24 Vac/dc. 	12008710	€ 330,00
	<p>TP1</p> <ul style="list-style-type: none"> - Lettore di prossimità con uscita dati formato Wiegand, 12Vdc, da abbinare alle centrali controllo accessi. - Proximity reader with Wiegand output, 12Vdc, to use with access control units. - Lecteur de proximité avec sortie données sous format Wiegand, 12Vdc, à couler aux centrales contrôle accès. - Lector de proximidad con salida datos formato Wiegand, 12Vdc, se acopla a las centrales control entrada. 	12008715	€ 120,00
	<p>TAG TP</p> <ul style="list-style-type: none"> - Tag di prossimità con portachiavi. - Proximity tag with key-ring. - Tag de proximité avec porte-clés. - Tag de proximidad con llavero. 	12008720	€ 8,00

SOLO MERCATO EXTRA EUROPEO / ONLY MARKET OUTSIDE EUROPE MERCHÉ EXTRA-EUROPÉEN / MERCADO EXTRA EUROPEO

CATALOGO / CATALOGUE / CATALOGUE / CATÁLOGO PAG. 57

	AKMY1 - Tx 1ch freq. 30/40 MHz – dip switch	12005200	€ 35,00
	AKMY2 - Tx 2ch freq. 30/40 MHz – dip switch	12005210	€ 36,00
	AKMY4 - Tx 4ch freq. 30/40 MHz – dip switch	12005220	€ 38,00
	ASMX1 - Tx 1ch freq. 300 MHz – dip switch	12000025	€ 29,00
	ASMX2 - Tx 2ch freq. 300 MHz – dip switch	12000030	€ 30,00
	ASMX4 - Tx 4ch freq. 300 MHz – dip switch	12000035	€ 32,00
	RMAS2 306 - Rx 1+3ch freq. 300 MHz – dip switch – in box / in box / en box / en caja	12000098	€ 88,00
	IB2 - Modulo radio / Radio module / Module radio / Módulos radio 30,875 MHz	12005730	€ 32,00

AUTOMAZIONE PER TENDE E TAPPARELLE / AUTOMATION FOR AWNINGS AND ROLLING SHUTTERS / AUTOMATION POUR STORES ET VOILETS ROULANT / AUTOMATISMOS PARA TOLDOS Y PERSIANAS









SENSORI CLIMATICI - CLIMATIC SENSORS - CAPTEURS CLIMATIQUES - SENSORES CLIMÁTICO

	<p>KAIROS SA</p> <ul style="list-style-type: none"> - Sensore climatico wireless. Sensore luce, vento, pioggia e temperatura. Autoalimentato con pannello fotovoltaico, trasmissione a 433,92MHz. - Wireless climatic sensor. Light, wind, rain and temperature sensor. Self-powered with photovoltaic panel, transmission at 433,92MHz. - Capteur climatique wireless. Capteur lumière, vent, pluie et température. Autoalimenté avec panneau photovoltaïque, transmission à 433,92MHz. - Sensor climático wireless. Sensor luz, viento, lluvia y temperatura. Autoalimentado con panel fotovoltaico, transmisión a 433,92MHz. 	12001770	€ 142,00
	<p>KAIROS DUO SA</p> <ul style="list-style-type: none"> - Sensore climatico wireless. Sensore luce e vento. Autoalimentato con pannello fotovoltaico, trasmissione a 433,92MHz. - Wireless climatic sensor. Light and wind sensor. Self-powered with photovoltaic panel, transmission at 433,92MHz. - Capteur climatique wireless. Capteur lumière et vent. Autoalimenté avec panneau photovoltaïque, transmission à 433,92MHz. - Sensor climático wireless. Sensor luz y viento. Autoalimentado con panel fotovoltaico, transmisión a 433,92MHz. 	12001772	€ 128,00
	<p>KAIROS PERGOLA SA</p> <ul style="list-style-type: none"> - Sensore climatico wireless. Sensore vento e pioggia. Autoalimentato con pannello fotovoltaico, trasmissione a 433,92MHz. - Wireless climatic sensor. Wind and rain sensor. Self-powered with photovoltaic panel, transmission at 433,92MHz. - Capteur climatique wireless. Capteur vent et pluie. Autoalimenté avec panneau photovoltaïque, transmission à 433,92MHz. - Sensor climático wireless. Sensor viento y lluvia. Autoalimentado con panel fotovoltaico, transmisión a 433,92MHz. 	12001774	€ 134,00
	<p>KAIROS</p> <ul style="list-style-type: none"> - Sensore climatico wireless. Sensore luce, vento, pioggia e temperatura. Alimentato da rete 100-240Vac, trasmissione a 433,92MHz. - Wireless climatic sensor. Light, wind, rain and temperature sensor. Mains supply 100-240Vac, transmission at 433,92MHz. - Capteur climatique wireless. Capteur lumière, vent, pluie et température. Alimenté depuis réseau 100-240Vac, transmission à 433,92MHz. - Sensor climático wireless. Sensor luz, viento, lluvia y temperatura. Alimentación de red 100-240Vac, transmisión a 433,92MHz. 	12001766	€ 128,00
	<p>KAIROS DUO</p> <ul style="list-style-type: none"> - Sensore climatico wireless. Sensore luce e vento. Alimentato da rete 100-240Vac, trasmissione a 433,92MHz. - Wireless climatic sensor. Light and wind sensor. Mains supply 100-240Vac, transmission at 433,92MHz. - Capteur climatique wireless. Capteur lumière et vent. Alimenté depuis réseau 100-240Vac, transmission à 433,92MHz. - Sensor climático wireless. Sensor luz y viento. Alimentación de red 100-240Vac, transmisión a 433,92MHz. 	12001765	€ 105,00
	<p>KAIROS PERGOLA</p> <ul style="list-style-type: none"> - Sensore climatico wireless. Sensore vento e pioggia. Alimentato da rete 100-240Vac, trasmissione a 433,92MHz. - Wireless climatic sensor. Wind and rain sensor. Mains supply 100-240Vac, transmission at 433,92MHz. - Capteur climatique wireless. Capteur vent et pluie. Alimenté depuis réseau 100-240Vac, transmission à 433,92MHz. - Sensor climático wireless. Sensor viento y lluvia. Alimentación de red 100-240Vac, transmisión a 433,92MHz. 	12001768	€ 125,00
	<p>AXEM</p> <ul style="list-style-type: none"> - Sensore climatico wireless. Sensore a vibrazione compatibile con le centraline HELIOS KAIROS e MICROCAP 16. Alimentazione con 2 batterie tipo AA 1,5V e trasmissione a 433,92MHz. - Wireless climatic sensor. Vibration sensor compatible with MICROCAP 16 control units. Powered by 2 batteries 1,5V AA type and transmission at 433,92MHz. - Capteur climatique wireless. Capteur à vibration compatible avec les centrales de commande HELIOS KAIROS et MICROCAP 16. Alimentation par 2 batteries type AA 1,5V et transmission à 433,92MHz. - Sensor climático wireless. Sensor a vibración compatible con las centrales HELIOS KAIROS y MICROCAP 16. Alimentación con 2 baterías de tipo AA 1,5V y transmisión a 433,92MHz. 	12001762	€ 60,00
	<p>KAIROS S</p> <ul style="list-style-type: none"> - Sensore vento. - Wind sensor. - Capteur vent. - Sensor viento. 	12001760	€ 45,00

	<p>WIN S Mini-sensore vento Mini-wind sensor Mini-capteur vent Mini-sensor viento.</p>	12001705	€ 25,80
---	---	----------	---------









CENTRALINE E TRASMETTITORI - CONTROL UNITS AND TRANSMITTERS - CENTRALES ET TRANSMETTEURS - CENTRALES Y MANDOS

	<p>HELIOS KAIROS - Centralina per tende da sole. Compatibile con le serie B.RO, CLARUS, KAIROS e AXEM. - Control unit for sunshades. Compatible with series B.RO, CLARUS, KAIROS and AXEM. - Centrale pour rideaux de soleil. Compatible avec les séries B.RO, CLARUS, KAIROS et AXEM. - Central para toldos. Compatible con las series B.RO, CLARUS, KAIROS y AXEM.</p>	12001821	€ 90,00
	<p>MICROCAP 16 - Centralina adatta per tende da sole con ricevitore a banda stretta. Compatibile con le serie B.RO, CLARUS, KAIROS e AXEM. - Control unit suitable for sunshades with narrow band receiver. Compatible with series B.RO, CLARUS, KAIROS and AXEM. - Centrale indiquée pour rideaux de soleil avec module radio à bande étroite. Compatible avec les séries B.RO, CLARUS, KAIROS et AXEM. - Central adecuada para toldos con módulo banda estrecha. Compatible con las series B.RO, CLARUS, KAIROS y AXEM.</p>	12006582	€ 64,00
	<p>B1VR PROX e B2VR PROX - Centralina per tende da sole con ingresso per anemometro. Compatibile con le serie B.RO e CLARUS, B1VR per 1 tenda, B2VR per 2 tende. Compatibile con sensori KAIROS S e WIN S. - Control unit for sunshades with anemometer input. Compatible with series B.RO and CLARUS, B1VR for 1 sunshade, B2VR for 2 sunshades. Compatible with KAIROS S and WIN S. - Centrale pour rideaux de soleil avec entrée pour anémomètre. Compatible avec les séries B.RO et CLARUS, B1VR pour 1 rideau, B2VR pour 2 rideaux. Compatible avec KAIROS S et WIN S. - Central para toldos con entrada para anemómetro. Compatible con las series B.RO y CLARUS, 1VR para 1 toldo, B2VR para 2 toldos. Compatible con KAIROS S y WIN S.</p>	B1VR PROX 12006608 B2VR PROX 12006621	€ 75,00 € 87,00
	<p>PROXIMA S - Centraline per tapparelle con ricevitore radio a banda larga. Compatibile con la serie B.RO e CLARUS. - Control units for roller shutters with broad band. Compatible with B.RO and CLARUS series. - Centrale pour rideaux avec récepteur à bande large. Compatible avec la série B.RO et CLARUS. - Central para persianas con radio receptor de banda larga. Compatible con la serie B.RO y CLARUS.</p>	12006595	€ 53,00
	<p>PROXIMA W - Centraline per tapparelle con ricevitore radio a banda stretta. Compatibile con la serie B.RO e CLARUS. - Control units for roller shutters with narrow band. Compatible with B.RO and CLARUS series. Miniaturized version with watertight box. - Centrale pour rideaux avec récepteur à bande étroite. Compatible avec la série B.RO et CLARUS. - Central para persianas con radio receptor de banda estrecha. Compatible con la serie B.RO y CLARUS.</p>	12006592	€ 58,00
	<p>PROXIMA M - Centraline per tapparelle con ricevitore radio a banda larga. Compatibile con la serie B.RO e CLARUS. Versione mini con box stagno - Control units for roller shutters with broad band. Compatible with B.RO and CLARUS series. Miniaturized version with watertight box. - Centrale pour rideaux avec récepteur à bande large. Compatible avec la série B.RO et CLARUS. Version miniaturisée avec boîte étanche. - Central para persianas con radio receptor de banda larga. Compatible con la serie B.RO y CLARUS. Versión mini con caja estanca.</p>	12006578	€ 54,00

	<p>PROXIMA M LAMP</p> <ul style="list-style-type: none"> - Centralina adatta per l'azionamento di luci a distanza attraverso comandi cablati e via radio. Compatibile con le serie CLARUS e B.RO. - Control unit suitable for the actuation of light at distance by wall switch or by radio. Compatible with the series CLARUS and B.RO transmitter. - Centrales indiquées pour l'actionnement des lumières à distance à travers des commandes câblées et par radio. Compatible con les séries CLARUS e B.RO. - Central adecuada para el funcionamiento de luces a distancia a través de mandos cableados y vía radio. Compatible con las series CLARUS y B.RO. 	12006577	€ 54,00
	<p>CLARUS I</p> <ul style="list-style-type: none"> - Trasmettitore a 1 canale con 3 tasti APRI, STOP e CHIUDI, fornito con supporto a muro. - Transmitters with 1 channel and 3 buttons OPEN, STOP, CLOSE, supplied with wall munt. - Transmetteur à 1 canal avec 3 touches OUVRE, STOP, et FERME, fourni avec support mural. - Mandos de 1 canal con 3 teclas ABRE, PARO y CIERRA, suministrado con soporte a pared. 	12006362	€ 31,00
	<p>CLARUS VI</p> <ul style="list-style-type: none"> - Trasmettitore a 6 canali con 3 tasti APRI, STOP e CHIUDI, fornito con supporto a muro. - Transmitters with 6 channels and 3 buttons OPEN, STOP, CLOSE, supplied with wall munt. - Transmetteur à 6 canaux avec 3 touches OUVRE, STOP, et FERME, fourni avec support mural. - Mandos de 6 canales con 3 teclas ABRE, PARO y CIERRA, suministrado con soporte a pared. 	12006357	€ 33,00
	<p>CLARUS XII</p> <ul style="list-style-type: none"> - Trasmettitore a 12 canali con 3 tasti APRI, STOP e CHIUDI, fornito con supporto a muro. - Transmitters with 12 channels and 3 buttons OPEN, STOP, CLOSE, supplied with wall munt. - Transmetteur à 12 canaux avec 3 touches OUVRE, STOP, et FERME, fourni avec support mural. - Mandos de 12 canales con 3 teclas ABRE, PARO y CIERRA, suministrado con soporte a pared. 	12006352	€ 36,00
	<p>B.RO WALL BB</p> <ul style="list-style-type: none"> - Trasmettitore da parete della serie B.RO per tende e tapparelle. - On wall transmitter of BIROL series for shutters and sunshades. - Transmetteur murale de la série B.RO pour stores et rideaux. - Emisor de pared de serie B.RO para toldos y persianas. 	12005117 12005121	€ 22,00 € 2,20
	<p>AV4</p> <ul style="list-style-type: none"> - Centralina per il comando manuale di 4 motori 230Vac. - Control unit for manual moving of 4 230Vac motors. - Centrale pour la commande manuelle de 4 moteurs 230Vac. - Central para el accionamiento manual de 4 motores 230Vac. 	12006583	€ 76,00
	<p>AV6</p> <ul style="list-style-type: none"> - Centralina per il comando di 6 motori 230Vac, ricevitore radio incorporato. - Control unit for 6 230Vac motors, incorporated radio receiver. - Centrale pour la commande de 6 moteurs 230Vac, récepteur radio incorporé. - Central para el accionamiento de 6 motores 230Vac, receptor radio incorporado. 	12006584	€ 180,00
	<p>AV10</p> <ul style="list-style-type: none"> - Centralina per il comando di 10 motori 230Vac, ricevitore radio incorporato. - Control unit for 10 230Vac motors, incorporated radio receiver. - Centrale pour la commande de 10 moteurs 230Vac, récepteur radio incorporé. - Central para el accionamiento de 10 motores 230Vac, receptor radio incorporado. 	12001830	€ 240,00

MOTORI TUBOLARI - TUBULAR GEARMOTORS - MOTEURS TUBULAIRES - MOTORES TUBOLARES

SERIE EURODRIVE CON FINECORSIA ELETTROMECCANICI / EURODRIVE SERIES WITH ELECTROMECHANICAL LIMIT SWITCHES /
SÉRIE EURODRIVE AVEC FINS DE COURSE ÉLECTROMÉCANIQUES / SERIE EURODRIVE CON FINALES DE CARRERAS ELECTROMECÁNICOS

		Ø Motore Ø Gearmotor Ø Moteur Ø Motor	Lunghezza Length Longueur Longitud	Carico Charge Charge Carga	Coppia Torque Couple Par	Velocità Speed Vitesse Velocidad	Potenza Power Puissance Potencia	Tensione Voltage Tension Tensión	Codice Code Code Código	Prezzo Price Prix Precio
	EURODRIVE 12 W/O	35 mm	506 mm	25Kg - Ø 40mm	12 Nm	17 rpm	168 W	230Vac - 50Hz	64000587	€ 77,00
	adattatori / adapters / adaptateurs / adaptadores 64100442+64100415 inclusi / included / inclus / Incluidos									
	EURODRIVE 20 W/O	45 mm	587 mm	35Kg - Ø 60mm	20 Nm	17 rpm	178 W	230Vac - 50Hz	64000588	€ 85,20
	adattatori / adapters / adaptateurs / adaptadores 64100445+64100400 inclusi / included / inclus / Incluidos									
	EURODRIVE 40 W/O	45 mm	590 mm	65Kg - Ø 60mm	40 Nm	12 rpm	282 W	230Vac - 50Hz	64000463	€ 89,25
	adattatori / adapters / adaptateurs / adaptadores 64100445+64100416+64100400 inclusi / included / inclus / Incluidos									
	EURODRIVE 60 W/O	45 mm	590 mm	90Kg - Ø 60mm	60 Nm	12 rpm	310 W	230Vac - 50Hz	64000464	€ 93,70
	adattatori / adapters / adaptateurs / adaptadores 64100445+64100416+64100400 inclusi / included / inclus / Incluidos									
	EURODRIVE 60 M/O	45 mm	590 mm	100Kg - Ø 60mm	60 Nm	12 rpm	310 W	230Vac - 50Hz	64000597	€ 137,70
	adattatori / adapters / adaptateurs / adaptadores 64100418+64100450+64100394+64100395 inclusi / included / inclus / Incluidos									
	EURODRIVE 120 W/O	59 mm	660 mm	135Kg - Ø 100 mm	100 Nm	12 rpm	450 W	230Vac - 50Hz	64000592	€ 226,80
	adattatori / adapters / adaptateurs / adaptadores 64100396+64100394 inclusi / included / inclus / Incluidos									
	EURODRIVE 120 M/O	59 mm	660 mm	135Kg - Ø 100 mm	120 Nm	12 rpm	450 W	230Vac - 50Hz	64000593	€ 244,50
	adattatori / adapters / adaptateurs / adaptadores 64100418+64100396+64100394+64100395 inclusi / included / inclus / Incluidos									
	EURODRIVE 230 M/O	92.4 mm	590 mm	290Kg - Ø 100 mm	230 Nm	12 rpm	830 W	230Vac - 50Hz	64000594	€ 490,00
	L'adattatore deve essere specificato nell'ordine / Adapter must be specified into the order / L'adaptateur doit être spécifique dans la commande / El adaptador tiene que ser especificado en el pedido									
	EURODRIVE 330 M/O	92.4 mm	590 mm	410Kg - Ø 100 mm	330 Nm	8 rpm	980 W	230Vac - 50Hz	64000595	€ 534,00
	L'adattatore deve essere specificato nell'ordine / Adapter must be specified into the order / L'adaptateur doit être spécifique dans la commande / El adaptador tiene que ser especificado en el pedido									

SEGUICI E CONTATTACI SU / FOLLOW AND CONTACT US IN



www.facebook.com/allmaticsrl/



www.instagram.com/allmaticsrl/



www.youtube.com/user/AllmaticSrl/videos

ASSISTENZA TECNICA / TECHNICAL SUPPORT





Allmatic s.r.l.
Via dell'Artigiano, 1.
32020. Borgo Valbelluna. Belluno. Italia
Tel. +39 0437 751175
info@allmatic.com
www.allmatic.com

